

RNC Series
10-3000 SCFM
Global Air Treatment



Experience Proven Results™

Durability Delivered

RNC Series refrigerated air dryers are engineered to benefit you today and tomorrow from the tradition of durability that is Gardner Denver. Quality components and engineering excellence meld to ensure you of a stable ISO Quality Class 4–5 pressure dew point. These exclusive compressed air preparation packages combine reliability, cutting-edge design, and innovative packaging into a single space saving unit. The air quality delivered from an RNC Series dryer may define the difference between moderate and superior results from your plant's processes or systems.

RNC Series dryers benefit you with:

- 1** Four levels of Intelligence Controller (I-Controller) packages to allow you to customize the RNC Series dryers to meet your specific requirements.
- 2** Select Heat Exchanger arrangements to ensure you get the right combination of value and efficiency in every size. This secures your investment today and tomorrow with energy efficiency.
- 3** Combination Separator/Filter that incorporates our 99% efficient 3 micron Grade B elements. This ensures you of consistent water removal (especially under low flow conditions.)



Air Treatment Systems

The flexibility engineered into every RNC Series dryer allows you to satisfy your air quality requirements with a single package. Enlist us to deliver the dew point stability, air quality, energy efficiency, and product reliability that you expect from Gardner Denver.

ISO 8573.1 Air Quality Classes

1992 earmarked the year the International Organization for Standardization (ISO) established ISO 8573.1 as the global benchmark for evaluating the quality of compressed air. Thus, providing engineers with a universally accepted unit of measure for quantifying compressed air stream contaminants. Namely Solid Particulates, Moisture, and Oil.

Standards per ISO 8573.1

Quality Classes	Solid Contaminants (maximum particle size in microns)	Maximum Pressure Dew Points		Maximum Oil Content (droplets, aerosols, and vapor ppm)	
		°F	°C	w/w	mg/m ³
0	as specified	as specified		as specified	
1	0.1	-94	-70	0.008	0,01
2	1	-40	-40	0.08	0,1
3	5	-4	-20	0.8	1
4	15	38	3	4	5
5	40	45	7	21	25
6	–	50	10	–	–

RNC Series packages deliver:

ISO 8573.1 QUALITY CLASS RATINGS			
RNC Series	Solids	Moisture*	Oil
As Standard, Grade B	3	4–5	5
with Cold Coalescer Option	1	4–5	1
with an optional external Grade G FIL Filter (shown attached)	1	4–5	0**

* Select models 100-3000 scfm deliver Class 4 dew points. Refer to the CAGI data sheets. RNC25-75 deliver 43-44 F dew points, Class 5. Class 4-5 accounts for all flow models. Refer to CAGI data sheets for dew point performance flow models 200-1000 scfm.

** Quality Class 0 reflects "as specified" level of cleanliness. The addition of an optional external Grade G Filter achieves 0.003 ppm w/w for technically Oil-Free air.



Built To Perform

Package Design

At first glance, the ruggedness and ease of serviceability engineered into RNC Series becomes apparent. Fabricated from solid steel, the corrosion resistant epoxy powder paint and the fit and finish of the cabinet, foretell of the quality to be found within. Easy interior access and user-friendly serviceability translate to reduced maintenance costs.

Proven Performance

All models use reliable refrigeration compressors and environmentally friendly refrigerants. Models through RNC500 use proven reciprocating refrigeration compressors. RNC600 through RNC3000 incorporate rugged scroll compressors. You benefit from long component life, and exceptional around-the-clock performance.

Effective Heat Transfer

RNC 10–15 models have the patented static condenser technology that eliminates the need for a cooling fan. These models include an on/off switch, longer power cord (8 ft), and pneumatically operated float drain.

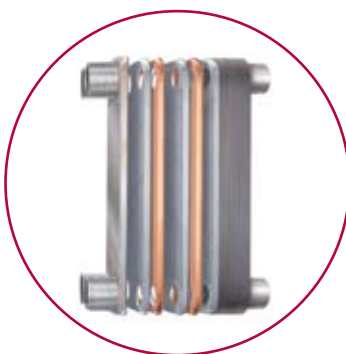

RNC Series models 25–3000 incorporate heat exchangers crafted from multiple offset layers of press formed AISI 316 stainless steel. Press forming creates peaks and valleys that form media channels that optimize fluid turbulence. This prevents fouling and maximizes energy efficiency.

High Performance Separator/ Filter

Effective moisture removal at all flow rates is the key to maintain dew point stability. RNC25 and larger includes Grade B two-stage cold filtration to ensure maximum water removal even under low flow conditions. Stage one separation, with dual stainless steel orifice tubes, removes bulk liquids and solids greater than 10 micron. Stage two utilizes in-depth fiber media to coalesce water droplets and captures solid particles 3 microns and larger.

Get Connected

The extended inlet/outlet connections on RNC dryers (RNC25–RNC750) were engineered with foresight to readily accept all FIL Series Filters without the need for cumbersome adaptors and fittings. RNC/1000–3000 inlet/outlet connections are on top of unit for ease of installation. Gain the installation flexibility needed today preparing you for the changes of tomorrow.

Premium WARRANTY

2 Years—Standard

3 Years—Extended

5 Years—Total Parts & Labor

Contact your local distributor
for more details.



Take Control

RNC Series dryers are equipped with control schemes that are designed to provide you with the most value delivered within each flow range. Engineered with industry leading features, each I-Controller package provides just the right level of benefits to appeal to the most challenging applications and demanding customers.

Instrumentation

Power-on LED and 8 foot grounded power cord are standard on all single-phase 115-volt units. Easy view angular instrumentation panels prominently display all I-Controllers instrumentation packages.

I-Controller Level 1

Standard equipment on models RNC25 through RNC100 includes: On/Off rocker switch, green power on light, temperature indicator and pneumatic, pilot-operated drain trap. Easy to monitor display panel.



I-Controller Level 2

Standard equipment* on models RNC125 through RNC750 includes: “Power-on” LED, “Compressor-on” LED, On/Off rocker switch, dew point bar graph LED display. Timed solenoid drain trap with push-to-test button and secondary manual drains complete with by-pass valves and drain lines are standard equipment. This helps keep the surrounding area clean and dry and helps you avoid having to shutdown the dryer during drain valve maintenance. Upgrade to I-Controller Level 2 optional on RNC25 - RNC100. Easy view angular panel.

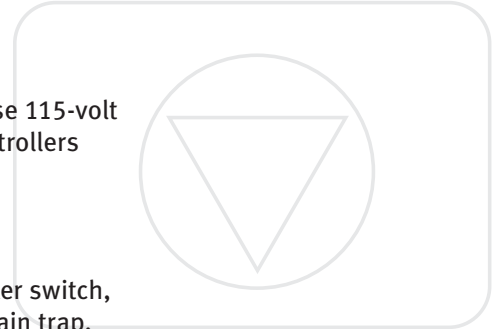
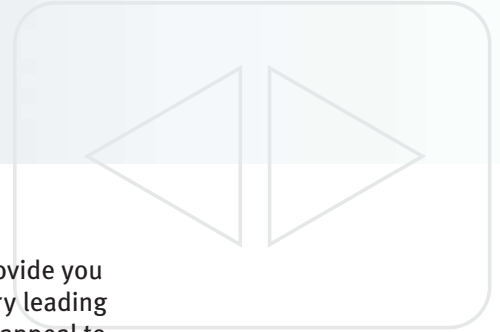

Compare These Features— Unmatched In The Industry!

I-Controller Level 3

Optional equipment on models RNC200 through RNC750 includes: LED indicated process diagram, remote start/stop, compressor run time, °F/°C selectable temperature readings for Inlet Air, Dew Point, and Ambient Air. Vivid yellow LED to advise when scheduled maintenance is due, and warn if high ambient or inlet air temperatures warrant attention. Alarm Mode triggers a bright red LED, initializes alarm relay and full text displays fault condition. Downloadable memory stores details of the last 10 alarm events (e.g., date, time, fault.) English, Spanish, French language selectable. Demand Drain with push-to-test button and secondary manual drains complete with by-pass valves and drain lines are standard equipment. This helps keep the surrounding area clean and dry and helps you avoid having to shutdown the dryer during drain valve maintenance. Easy view angular panel.

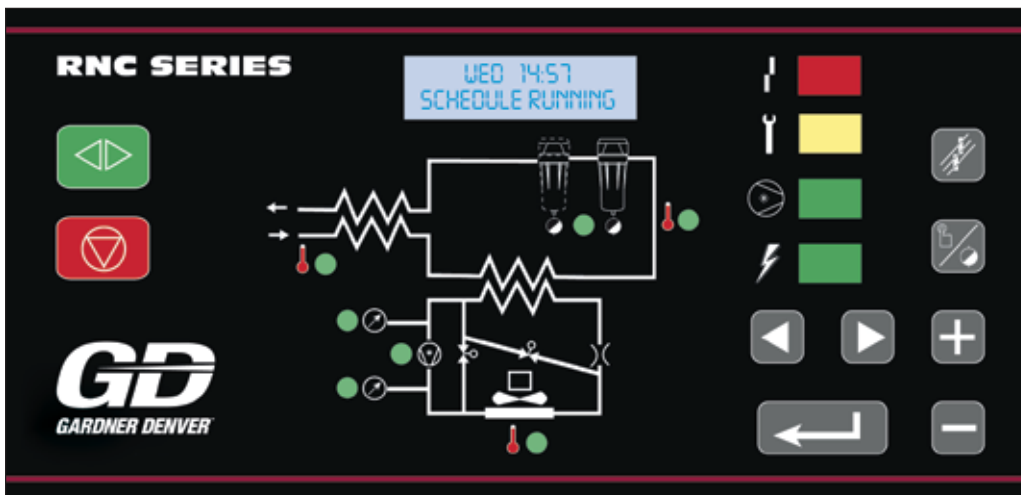

I-Controller Level 4

Standard equipment on models RNC1000 through RNC3000 includes: manual mode, schedule mode to synchronize operation to your workday, auto restart, text display window that displays current time, operating mode, total operating hours, hours to service, dew point bar graph LED display, compressor-on light, power-on light, temperature indicator, alarm/service light, reset button, set/run button, programming buttons, on/off button, drain push-to-test button, English, Spanish, German, French and Italian language selectable, RS-232 communication capable, fault condition diagnostics with text display, dry contacts for high dewpoint remote alarm at 55°F. Easy view angular panel.



Refrigeration Circuit

RNC Series dryers enlist proven components and modern materials to deliver the durability you expect from Gardner Denver. Hot, moist incoming compressed air enters the Precooler/Reheater (1) where it is pre-cooled by the cold dehydrated airstream. Environmentally friendly low-pressure refrigerant gas is pressurized in the refrigeration compressor (2). Once compressed into a high-pressure gas, it then flows through the condenser (3) and changes to a cold 35°F liquid. The thermal expansion valve (4) precisely meters the cold liquid refrigerant into the evaporator (5) where the work is done. Hot, saturated compressed air enters the evaporator at the end opposite the incoming liquid refrigerant. The compressed air is chilled as they cross paths. Water is condensed out of the cold exiting air and is efficiently removed in the Separator/3 micron Filter (6). The cold air stream then flows through (7) the Cold Coalescing Oil Removal Filter (optional on models RNC25–RNC3000) where oil droplets and aerosols to 0.008 ppm w/w are captured and removed. The exiting cold, dry compressed air then reenters the Precooler/Reheater (1) where it is reheated by the hot incoming air to prevent pipe sweating in your plant. Finally, the warm refrigerant is now a low-pressure gas and returns to the suction-side (8) of the refrigeration compressor to continue the process.

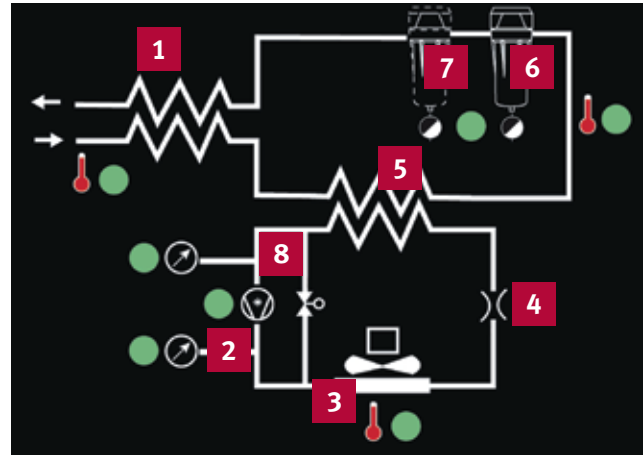

LEGEND:

- | | |
|-----------------------------------|--|
| 1 Precooler/Reheater | 6 Moisture Separator/
3 micron Filter |
| 2 Refrigeration Compressor | 7 Optional Cold
Coalescing Oil
Removal Filter |
| 3 Condenser | 8 Suction-side |
| 4 Thermal Expansion Valve | |
| 5 Evaporator | |

RNC 10–15

Warm saturated air enters the Evaporator (A), where it is cooled by an air-to-refrigerant process. Water vapor condenses into a liquid for removal at the moisture separator (B) by an Automatic Drain (C). The cold, dry air is reheated as it passes through the Reheater (D) while the patented Static Condenser (E) radiates waste heat to ambient. This eliminates the need for a cooling fan and prevents pipeline sweating at the air outlet.

A Constant Pressure (F) Expansion Valve (CPEV) modulates the flow of liquid refrigeration to the Evaporator (A). This eliminates freeze-ups and assures continuous, automatic dew point control. The CPEV responds to pressure changes as the refrigerant leaves the Evaporator. This maintains the proper cooling rate under all load conditions. The CPEV is adjusted at the factory to deliver automatic operation.

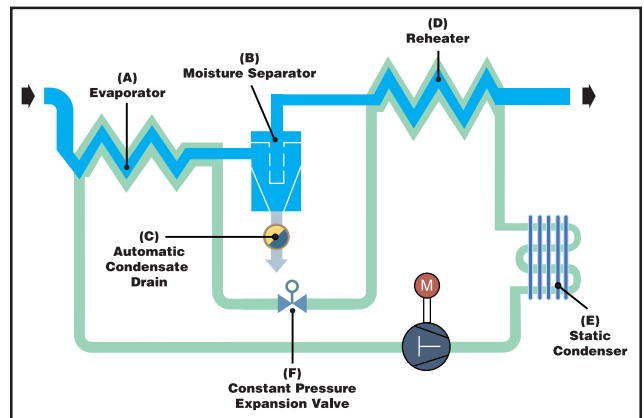

LEGEND:

- | | |
|-----------------------------|---|
| A Evaporator | D Reheater |
| B Moisture Separator | E Static Condenser |
| C Automatic Drain | F Constant Pressure
Expansion Valve |

System Options

Power-on LED and 8 foot grounded power cord are standard on all single-phase 115-volt units. Easy view angular instrumentation panels prominently display all I-Controllers instrumentation packages.

Option Feature Overview

Control Version	LED Indicator lights			Drain Valves			System Upgrades	
	Power-on	Compressor-on	Dew Point Indication	Pneumatic Pilot-Operated	Timed Drain with Push-to-test*	Demand Drain with Oil Removal Filter	Cold Coalescing Oil Removal Filter	Vacuum Fluorescent Text Display
I-Controller Level 1	S	S	S	S	-	-	O	-
I-Controller Level 2	S	S	S	-	S	-	O	-
I-Controller Level 3	S	S	-	-	-	S	O	S
I-Controller Level 4	S	S	S	-	-	-	O	S

S = Standard Feature; O = Optional Feature; * Secondary manual drains complete with by-pass valves are standard equipment and only available on packages with Level 2, Level 3, and Level 4 I-Controllers. This helps keep the area clean and dry and helps you avoid dryer shutdown during drain valve maintenance.

Oil Removal... this option integrates our factory installed Grade E Cold Coalescing Oil Removal Filter. Oil droplets and aerosols are extracted from the air stream in cleaning it down to 0.008 ppm w/w and solids are retained down to 0.01 micron. RNC Series dryers that include the Cold Coalescing Oil Removal Filter option are also equipped with a dedicated drain trap. Drain trap is consistent with the type provided with your chosen I-Controller. Available on models RNC25–RNC3000

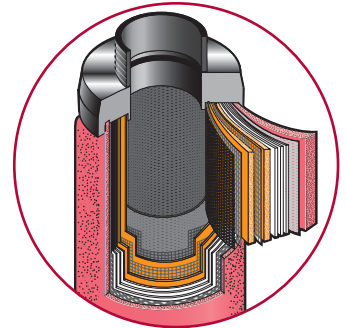

Low Ambient... this option protects the dryer from internal damage due to freezing temperatures down to -10°F. Factory installed package includes heat tracing, thermostat and insulation for the separator bowl.

Gauges... four panel mounted gauges: air inlet temperature, air outlet pressure, refrigerant suction pressure and refrigerant head pressure.

Dry Contacts... remote bulb temperature switch with "C"-Form contacts; mounted inside cabinet.

Air-Bypass Piping... Three valve block and bypass; mounts to inlet/outlet connections; shipped loose. MWP 200psig



RNC Series Refrigerated Dryer-Filter Specifications

Model RNC	Rated Flow ⁽¹⁾	Standard I-controller ⁽²⁾	Connection (In) ⁽³⁾	Dimensions (IN)			Weight (lbs)	w/Oil removal filter (lbs)	voltages (v/ph/hz)	kW	Dryer Model Number	Kits for Dryers	Kits for Dryers Mfg. After June 15, 2006	
				H	W ⁽⁴⁾	D								
10	10	I-Controller Level 1	3/8 OD	14	11	16	64	115/1/60	115/1/60	.21	RNC 5, 10, 15 (UNITS MFG BEFORE 10/15/03)	RNCMK1	N/A	
15	15		3/8 OD	14	11	16	69				RNC 25, 35	RNCMK2	RNCMK2	
25	25		1/2 NPT	26	20.5	18	86				147	RNC 25, 35 W/ OPTION F	RNCMK12	RNCMK12
35	35		1/2 NPT	26	20.5	18	90				151	RNC 50	RNCMK3	RNCMK3
50	50		1/2 NPT	26	20.5	18	95				157	RNC 50 W/ OPTION F	RNCMK13	RNCMK13
75	75		3/4 NPT	26	20.5	18	106				216	RNC 75, 100	RNCMK4	SEE BELOW
100	100	1 NPT	38	29	20	251	258	220-240/1/50	.93	RNC 75, 100 W/ OPTION F	RNCMK14	SEE BELOW		
125	125	I-Controller Level 2	1 NPT	38	29	20	273	208-230/3/60 460/3/60 575/3/60 380-420/3/50	208-230/3/60	1.28	RNC 100	N/A	RNCMK22S	
150	150		1 NPT	38	29	20	279				287	RNC 100 W/ OPTION F	N/A	RNCMK42S
200	200		1-1/2 NPT	39	34	32	425				438	RNC 125, 150	RNCMK5	RNCMK23S
250	250		1-1/2 NPT	39	34	32	463				476	RNC 125, 150 W/ OPTION F	RNCMK15	RNCMK43S
300	300		1-1/2 NPT	46	35	32	527				540	RNC 200, 250	RNCMK6	RNCMK24S
400	400		2 NPT	46	35	32	571				603	RNC 200, 250 W/ OPTION F	RNCMK16	RNCMK44S
500	500		2-1/2 NPT	58	32	42	684				716	RNC 300	RNCMK7	RNCMK25S
600	600		2-1/2 NPT	58	32	42	646				691	RNC 300 W/ OPTION F	RNCMK17	RNCMK45S
750	750		2-1/2 NPT	58	32	42	734				804	RNC 400, 500	RNCMK8	RNCMK26S
1000	1000		I-Controller Level 4	3 ANSI flange	85	49	41				1146	1173	208-230/3/60	2.68
1250	1250	4 ANSI flange		85	49	51	1521	1548	460/3/60	RNC 600	N/A	RNCMK27S		
1500	1500	4 ANSI flange		85	49	51	1547	1574	575/3/60	RNC 600 W/ OPTION F	N/A	RNCMK47S		
1750	1750	6 ANSI flange		85	55	60	1940	1994	380-420/3/50	RNC 750	RNCMK9	RNCMK28S		
2000	2000	6 ANSI flange		85	55	60	1986	2040		RNC 750 W/ OPTION F	RNCMK19	RNCMK48S		
2500	2500	6 ANSI flange		85	55	60	2315	2369		RNC 1000, 1250, 1500 W/ OPTION F	RNCMK10	RNCMK29S		
3000	3000		6 ANSI flange	85	55	60	2646	2700		11.3	RNC 1000, 1250, 1500 (MFG 1/15/02 - 6/14/06)	RNCMK10-5	RNCMK29S	
										11.5	RNC 1000, 1250, 1500 W/ OPTION F (MFG 1/15/02 - 6/14/06)	RNCMK20	RNCMK49S	
										15.0	RNC 1750, 2000, 2500, 3000 W/ OPTION F (MFG 1/15/02 - 6/14/06)	RNCMK11	RNCMK30S	
										19.7	RNC 1750, 2000, 2500, 3000 (MFG 1/15/02 - 6/14/06)	RNCMK21	RNCMK50S	
												RNCMK11-5	RNCMK30S	

* Consult your local Distributor for information on complete maintenance kits

Refrigerant: RNC10-RNC750 use R-134a, models RNC1000-RNC3000 use R-404a

Maximum operating pressure: 250 PSIG for packages with I-Controller Level 1 & 2; 232 PSIG for packages with I-Controller Level 3 & 4

Maximum operating temperature: 130°F:

(1) Rated Flow Capacity - Conditions for rating dryers are in accordance with CAGI (Compressed Air and Gas Institute) Standard ADF100: Refrigerated Compressed Air Dryers - Methods for Testing and Rating. Conditions for rating above dryers are: compressed air at dryer inlet: 100 psig and 100°F saturated; ambient temperature: 100°F; operating on 60 Hz power supply. For dew point performance ratings, models RNC200-RNC1000, request a CAGI data sheet from your local distributor.

(2) I-Controller Level 4 is standard on RNC1000-RNC3000
I-Controller Level 3 is available on RNC200-RNC750
I-Controller Level 2 is standard on RNC125-RNC750
I-Controller Level 1 is available on RNC25-RNC100

(3) OD connection is tubing; NPT connections are male

(4) Add 2 inches for Inlet/Outlet connections (does not apply to RNC10-RNC15 or RNC1000-RNC3000)

(1) CSA/UL and CE certified

(2) NEMA 1 standard

f. Units are air-cooled as standard. Contact your local Distributor if water-cooled versions are required.

Table 1 – Correction Factors (Multipliers) for Inlet Air Temperature & Pressure

Inlet Pressure (PSIG)	Inlet Temperature				
	80°F (27°C)	90°F (32°C)	100°F (38°C)	110°F (43°C)	130°F (54°C)
50	1.35	1.05	0.84	0.69	.44
80	1.50	1.17	0.95	0.79	.52
100	1.55	1.23	1.00	0.82	.56
125	1.63	1.31	1.07	0.91	.61
150	1.70	1.37	1.13	0.95	.64
175	1.75	1.42	1.18	0.99	.68
200	1.80	1.47	1.22	1.03	.72

CAPACITY CORRECTION FACTORS

To adjust dryer capacity for conditions other than rated, use Correction Factors (multipliers) from Tables 1 and 2.

Example: What is the capacity of a 1,000 scfm model when the compressed air at the inlet to the dryer is 150 psig and 100°F (38°C), and the ambient temperature is 90°F (32°C)?

Answer: 2,000 scfm (rated flow from Specifications Table) x 1.08 (correction factor for inlet temperature and pressure from Table 1) x 1.06 (correction factor for ambient temperature from Table 2) = 2,290 scfm

Table 2 – Correction Factors for Ambient Temperature

Ambient Temperature	80°F (27°C)	90°F (32°C)	100°F (38°C)	110°F (43°C)
Multiplier	1.12	1.06	1.00	0.94

50 Hz operation: Derregulate for 50 Hz operation. Apply the correction factor of .8333 to flow temperature and pressure.



www.GardnerDenverProducts.com maggie@gardnerdenver.com

Gardner Denver, Inc. 1800 Gardner Expressway, Quincy, IL 62305
Customer Service Department

Telephone: (800) 682-9868 FAX: (217) 224-7814

©2009 Gardner Denver, Inc. Litho in U.S.A. GA-RNC-100 3rd Ed. 9/09



Member



Please recycle after use.