

C-SERIES CLAW | VACUUM PUMP

VLR-62/VLR-122



Elmo Rietschle VLR-62/122

Elmo Rietschle brand claw vacuum pumps offer reliable long life performance in demanding applications operating with virtually no maintenance. Two counter rotating claws rotate in a contact-less oil-free pumping chamber, operating with tight clearances to ensure quiet, clean and efficient vacuum service.

Custom tailor your claw pump to the application. Two new model sizes are now available in two different variants which allows you to select the right pump to best fit the application. Our “passive” cooled version is ideal to replace carbon vane, liquid ring and oil lubricated rotary vane vacuum pumps in applications requiring down to 18 inHg vacuum. Our “active” cooled version employs a pump cooling fan in a compact very quiet pump designed for applications requiring a vacuum level down to 27 inHg. Combining these pumps with a VFD control are ideal candidates for savings credits and rebates from local power companies.

Dry Vacuum

Oil-less vacuum allows for clean performance without the hassle and expense of carbon vane and oil lubricated rotary vane pumps. No more messy oil and exhaust filters to change or expensive carbon vanes to replace, not to mention the downtime and expense incurred to perform these shorter maintenance intervals. Elmo Rietschle claw pumps have service intervals up to 5 years.

Capabilities

- Virtually No Maintenance
- Service Intervals up to 5 Years
- Extremely Power Efficient
- Oil-Free Compression
- Low Noise Levels (63 dB, VLR-62 active)
- Higher Flow Rates than Rotary Vane
- Environmentally Friendly
- Ideal for Operation on VFD

TAILOR-MADE SOLUTIONS FOR YOUR APPLICATION

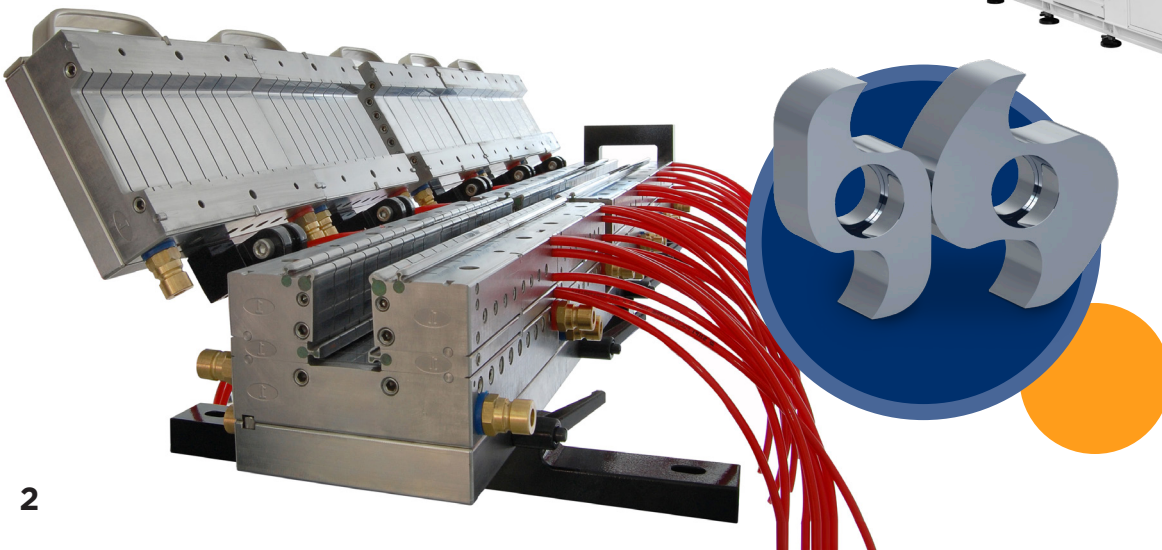

VLR-62/122 Active 27 inHg

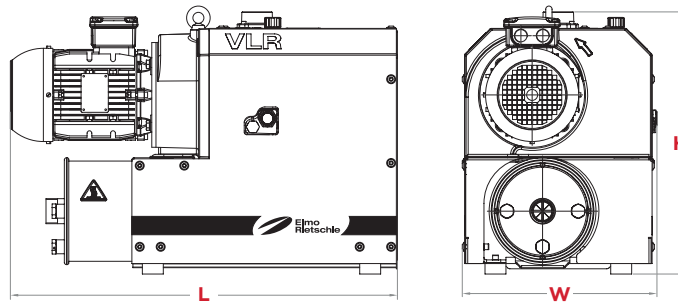

VLR-62 Passive 18 inHg

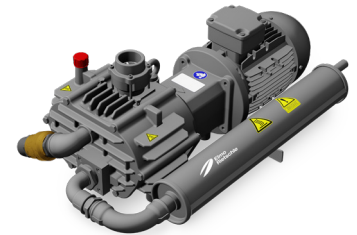
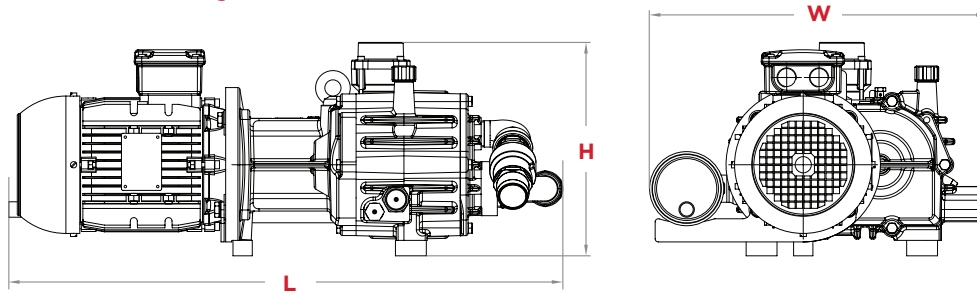

VLR-122 Passive 18 inHg

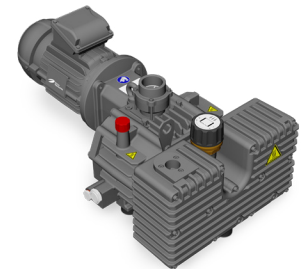
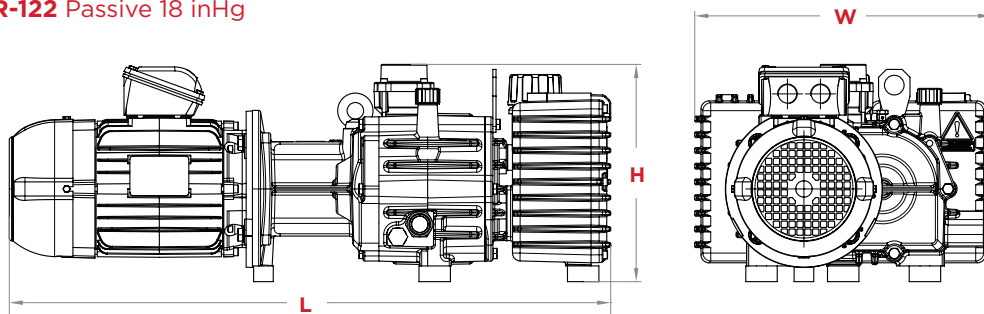

SPECIFICATIONS

MODEL	CFM		BASE PRESSURE		IN/OUT	WEIGHT		DIMENSIONS H × W × L	
	50 HZ	60 HZ	MBARA	INHG		LBS	KG	INCHES	MM
VLR62(01)	36.5	43.5	400	17.85	1-1/2	154	70	10.9 × 13.4 × 27.8	276 × 340 × 707
VLR122(01)	70.6	84.8	400	17.85	1-1/2	212	96	10.9 × 14.9 × 30.1	276 × 378 × 766
VLR62(31)	36.5	43.5	100	26.97	1-1/2	251	114	19.7 × 14.6 × 29.1	500 × 372 × 739
VLR122(31)	70.6	84.8	100	26.97	1-1/2	265	120	19.7 × 14.6 × 30.3	500 × 372 × 770

The leader in every market we serve
by continuously improving all business processes
with a focus on innovation and velocity



www.ElmoRietschle.com

©2024 Industrial Technologies and Services, LLC.
Printed in U.S.A.
ER-C-VLR-62-122 2nd Ed. 8/24



 Please recycle after use.