

HORIZONTAL AIR RECEIVERS WITH FEET ONLY

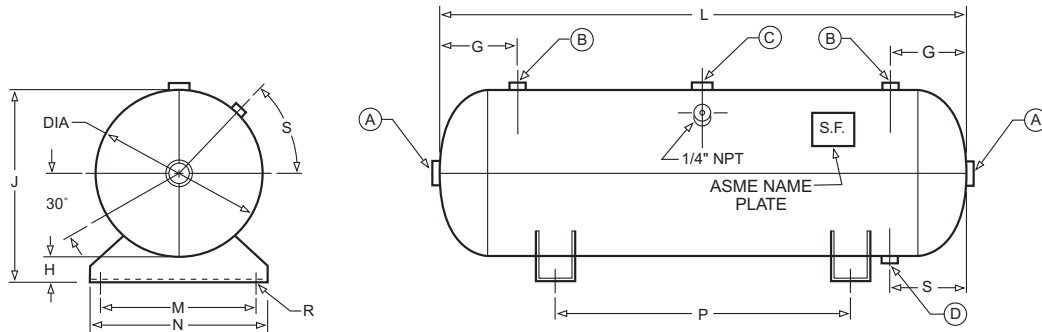

P/N	GAL	DIA	L	OPENINGS (NPT)"				DIMENSIONS "										
				A	B	C	D	E	F	G	H	J	T	M	N	P	R	S
A10023*	12	12	27	3/4	1/2	1/2	1/4	-	-	5-1/2	1-3/16	13-3/16	-	11	12	14	1/2	5-1/2
A10025*	20	14	33	1-1/2	1/2	1/2	1/4	-	-	6	2	16	-	14	15-1/2	18	1/2	6
A10027	30	16	38	1-1/2	1/2	3/4	1/4	-	-	6	2-1/2	18-1/2	-	15	19	18	9/16x1	6
A10029	60	20	48	2	3/4	1	1/2	-	-	7-3/4	3-3/16	23-3/16	-	18-3/4	21	26	9/16x1	7-1/4
A10031	80	20	63	2	1	1-1/2	3/4	-	-	9	3-3/16	23-3/16	-	18-3/4	21	36	9/16x1	9
A10033	120	24	69	2	1-1/2	1-1/2	3/4	-	-	10	3-1/2	27-1/2	-	23-3/4	26-1/2	42	9/16x1	9
A10035	200	30	72	2	2	2	1	-	-	12	4	34	-	27-1/2	30	42	9/16x1	10-1/4
A10037	240	30	84	2	2	2	1	-	-	12	4	34	-	27-1/2	30	54	9/16x1	10-5/8

HORIZONTAL AIR RECEIVERS WITH FEET AND TOPPLATE

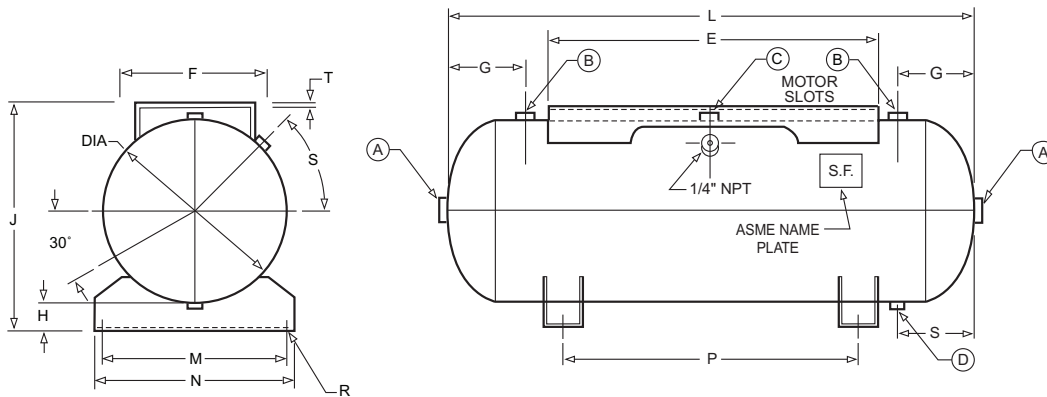

P/N	GAL	DIA	L	OPENINGS (NPT)"				DIMENSIONS "										
				A	B	C	D	E	F	G	H	J	T	M	N	P	R	S
A10024*	12	12	27	3/4	1/2	1/2	1/4	15	9	5-1/2	1-3/16	14-5/8	3/16	11	12	14	1/2	5-1/2
A10026*	20	14	33	1-1/2	1/2	1/2	1/4	19	10	6	2	17-1/2	3/16	14	15 1/2	18	1/2	6
A10028	30	16	38	1-1/2	1/2	3/4	1/4	24	12	6	2-1/2	20	3/16	15	19	18	9/16x1	6
A10030	60	20	48	2	3/4	1	1/2	30	14	7-3/4	3-3/16	24-3/4	3/16	18-3/4	21	26	9/16x1	7-1/4
A10032	80	20	63	2	1	1-1/2	3/4	36	14	9	3-3/16	24-3/4	3/16	18-3/4	21	36	9/16x1	9
A10034	120	24	69	2	1-1/2	1-1/2	3/4	44	16	10	3-1/2	29-1/4	1/4	23-3/4	26-1/2	42	9/16x1	9
A10036	200	30	72	2	2	2	1	44	18	12	4	35-13/16	1/4	27-1/2	30	42	9/16x1	10-1/4
A10038	240	30	84	2	2	2	1	48	18	12	4	35-13/16	1/4	27-1/2	30	54	9/16x1	10-5/8

*12 and 20 Gal. receivers have 4 pressed steel feet. All others have channel as shown.

Note: Receivers listed above are available without feet and topplate (slick receivers).

• All volume capacities listed in this brochure are U.S. gallons. • All dimensions listed in this brochure are subject to change without notice.

For installation dimensions consult factory.

HORIZONTAL AIR RECEIVERS WITH EXTENDED TOPPLATE

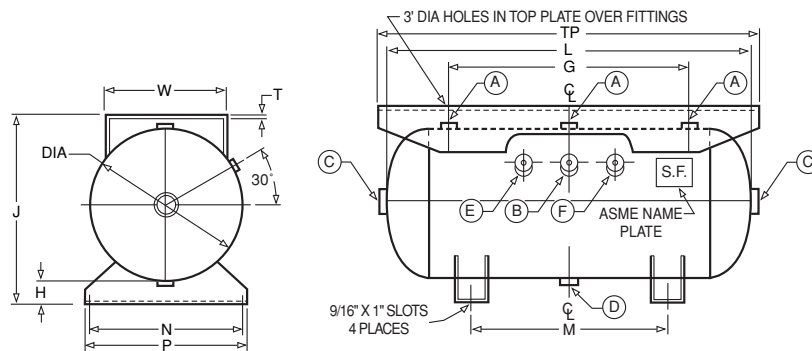

P/N	GAL	DIA	L	OPENINGS (NPT)"								DIMENSIONS "							
				J	A	B	C	D	E	F	G	TP	W	T	M	N	P	H	
A10136	30	16	38	20	3/4	1/4	1-1/2	1/4	3/8	1/4	26-1/2	40	12	3/16	22	15	19	2-1/2	
A10137	60	20	48	25-1/2	3/4	1/4	2	1/2	3/8	1/4	31-1/2	50	16	1/4	26	18-3/4	21	3-3/16	
A10138	80	20	63	25-1/2	1-1/4	1/4	2	3/4	3/8	1/4	45	66	16	1/4	36	18-3/4	21	3-3/16	
A10139	120	24	69	29-13/16	2	1/4	2	3/4	3/8	1/2	48	74	16	1/4	42	23-3/4	26-1/2	3-1/2	
A10140	200	30	72	36-1/2	2	1/4	2	1	3/8	1/2	48	86	18	1/4	42	27-1/2	30	4	
A10141	240	30	84	36-1/2	2	1/4	2	1	3/8	1/2	61	96	18	1/4	54	27-1/2	30	4	

HORIZONTAL WITH PEDESTAL FEET - LESS TOPPLATE

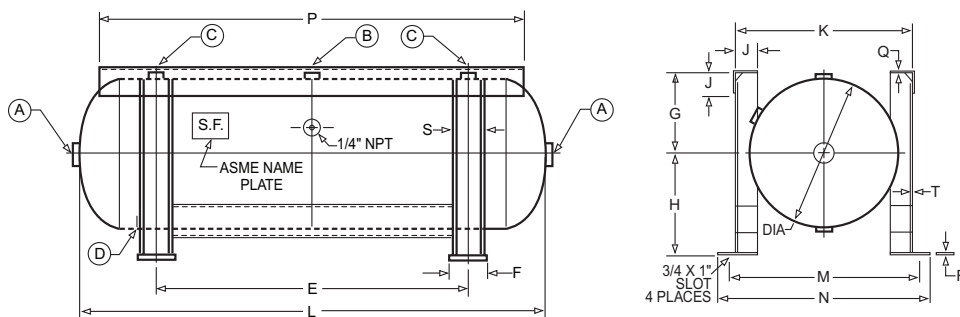

P/N	GAL	DIA	L	OPENINGS (NPT)"								DIMENSIONS "											
				A	B	C	D	E	F	G	H	J	K	T	M	N	P	Q	R	S			
A10123	30	16	38	1-1/2	1-1/2	1/2	1/4	22	4	9	12	2.63	19.31	.134	22	24.5	31	.135	.25	3			
A10124	60	20	48	2	1-1/2	1-1/2	1/2	27	5	11	14	3.19	24.38	.135	26	28.5	42	.188	.25	4			
A10125	80	20	63	2	1-1/2	1-1/2	3/4	42	5	11	14	3.19	24.38	.135	26	28.5	57	.188	.25	4			
A10126	120	24	69	2	1-1/2	1-1/2	3/4	42	7	13	16	4.19	30.38	.188	32	34.5	61	.188	.38	6			
A10127	200	30	72	2	1-1/2	1-1/2	1	42	10	16	19	5.25	36.5	.188	40	42.5	60	.25	.5	9			
A10128	240	30	84	2	1-1/2	1-1/2	1	54	10	16	19	5.25	36.5	.188	40	42.5	72	.25	.5	9			

GASOLINE DRIVEN UNITS

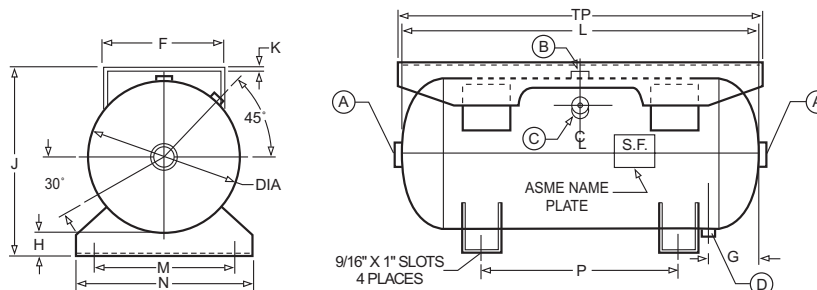

P/N	GAL	DIA	L	OPENINGS (NPT)"				DIMENSIONS "									
				A	B	C	D	F	G	H	J	K	L	M	N	P	TP
A10039	30	16	38	1-1/2	3/4	1/4	1/4	13	5-1/2	2-1/2	20	1/4	38	15	19	20-3/4	38-1/2

VERTICAL AIR RECEIVERS

With Topplate

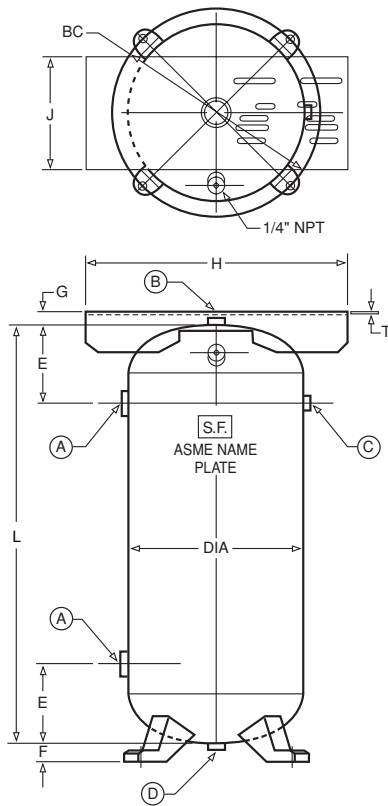

Less Topplate

DESIGN A

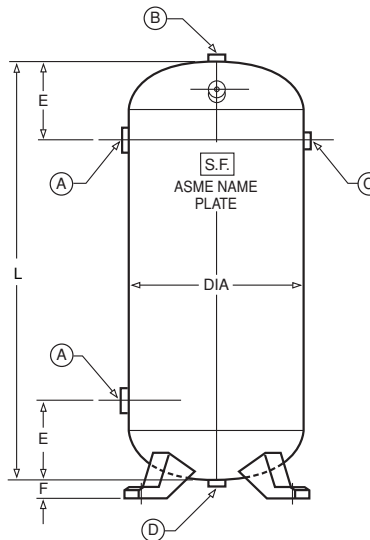
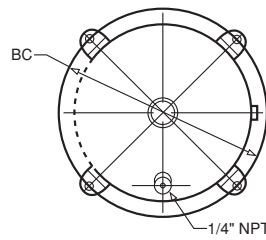

DESIGN B

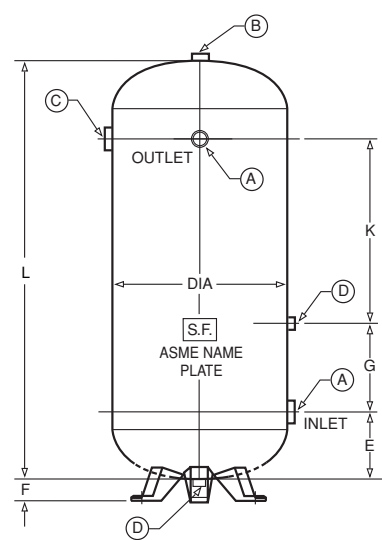
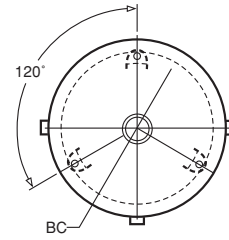

WITH TOPPLATE					OPENINGS (NPT)"				DIMENSIONS "							
P/N	GAL	DIA	L	PSI	A	B	C	D	E	F	G	H	J	K	T	BC
A10041	30	16	38	200	1-1/2	1/2	1/4	1/4	8	1-3/4	1-1/2	23	9	-	3/16	18-3/4
A10044	60	20	48	200	2	3/4	1/4	1/4	9	2-1/4	1-1/2	30	13	-	3/16	23-3/4
A10046	80	24	46	200	2	1	1/4	1/2	11	3-3/8	1-1/2	30	13	-	3/16	25-1/2
A10047*	120	30	46	200	2	1	1/4	1/2	12	6	3-7/8	39	15	-	1/4	26

DESIGN A - LESS TOPPLATE

A10040	30	16	38	200	1-1/2	1/2	1/4	1/4	8	1-3/4	-	-	-	-	-	18-3/4
A10043	60	20	48	200	2	3/4	1/4	1/4	9	2-1/4	-	-	-	-	-	23-3/4
A10045	80	24	46	200	2	3/4	1/4	1/2	11	3-3/8	-	-	-	-	-	25-1/2

DESIGN B - LESS TOPPLATE

A11175	80	20	63	200	2	1	1/2	1/2	10	2-1/4	21	-	-	22	-	23-3/4
A11176	120	24	69	200	2	1	1/2	1/2	12	3-3/8	26	-	-	18	-	25-1/2
A11177	200	30	72	200	2	1	1/2	1/2	12	3-3/8	15	-	-	32	-	25-1/2
A11178	240	30	84	200	2	1	1/2	1/2	12	3-3/8	19	-	-	40	-	25-1/2

* Skirt instead of pressed steel feet

INDUSTRIAL VERTICALS

20' to 36' Diameter

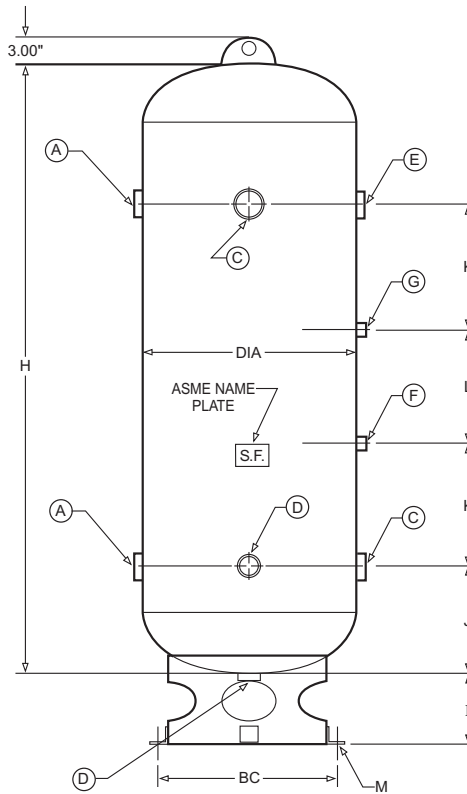

P/N	PSI	GAL	DIA	H	OPENINGS (NPT)"							DIMENSIONS "					
					A	C	D	E	F	G	I	J	K	L	M	BC	
A10325	200	80	20	63	2	2	1/2	3/4	1/2	1/4	6	10	11	21	11/16	17	
A10049	200	120	24	69	2	2	1	1-1/2	1/2	1/4	8	12	14	13	11/16	20	
A10051	200	200	30	72	2	2	1	2	1/2	1/4	8	12	16	15	11/16	26	
A10053	200	240	30	84	2	2	1	2	1/2	1/4	8	12	20	19	11/16	26	
A10054	137	400	36	93	2	3	1	2-1/2	1/2	1/4	8	16	20	20	11/16	32	
A10055	165																
A10056	200																
A10129	165	500	36	117	2	3	1	3	1/2	1/4	8	18	26	25	11/16	32	
A10130	200																

Note: Other sizes and pressures are available upon request.

INDUSTRIAL VERTICALS

42" Diameter and above

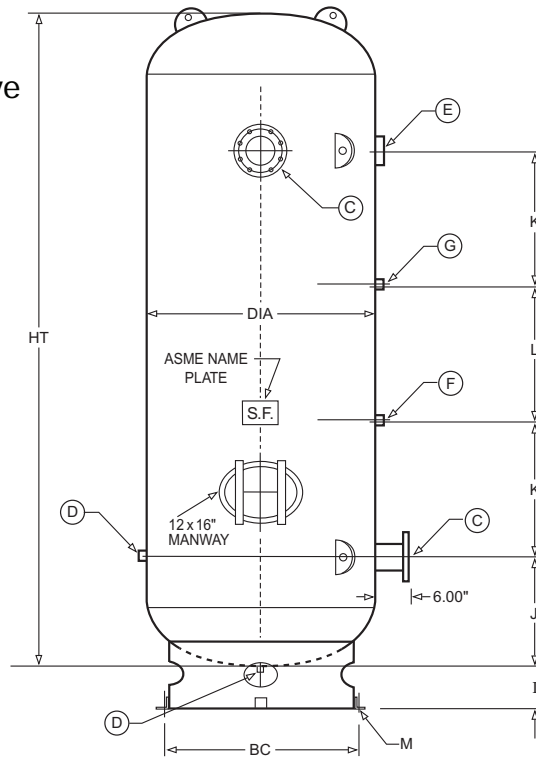

P/N	PSI	GAL	DIA	HT	FLANGE		OPENINGS (NPT)"					DIMENSIONS"					
					C	D	E	F	G	I	J	K	L	M	BC		
A10131*	150	660	42	120	-	4	1	3	1	1/4	8	20	25	25	11/16	38	
A10132*	150	1060	48	144	-	6	1	3	1	1/4	8	24	32	32	11/16	38	
A10330*	190	1350	54	148	-	6	1-1/4	3	1	1/4	8	26	32	32	11/16	44	
C102832	137																
C102866	165																
A10300	137	1550	54	166	-	6	1-1/4	3	1	1/4	8	26	38	38	11/16	44	
C102833	150	1660	60	150	-	6	1-1/4	3	1	1/4	8	26	32	30	11/16	44	
A10333	150	2000	60	174	-	6	1-1/4	3	1	1/4	8	26	38	38	11/16	44	
A10336	150	2560	60	220	-	6	1-1/4	3	1	1/4	8	26	56	56	11/16	44	
A10064	125	3000	66	214	-	6	1-1/4	3	1	1/4	8	26	46	46	11/16	50	
A10339	137																
A10065	125	3800	72	228	-	6	1-1/4	3	1	1/4	8	30	56	56	11/16	58	
A10340	150	4500	78	235	-	6	1-1/4	3	1	1/4	8	34	50	67	7/8	58	
C101557	125																
C101558	150																
C101559	125	5200	84	238	-	6	1-1/4	3	1	1/4	8	34	50	70	7/8	-	
C101560	150																
C101561	125	6000	90	241	-	6	1-1/4	3	1	1/4	8	36	50	72	7/8	-	
C101562	150																
C101563	125	7000	96	244	-	6	1-1/4	3	1	1/4	8	38	50	68	7/8	-	
C101564	150																
C101565	125	8000	102	247	-	6	1-1/4	3	1	1/4	8	40	50	70	7/8	-	
C101566	150																

* These designs have lifting lugs on top head only.
Note: Other sizes and pressures are available upon request.

WALL - TRUCK - CEILING MOUNTS FOR SLICK RECEIVERS

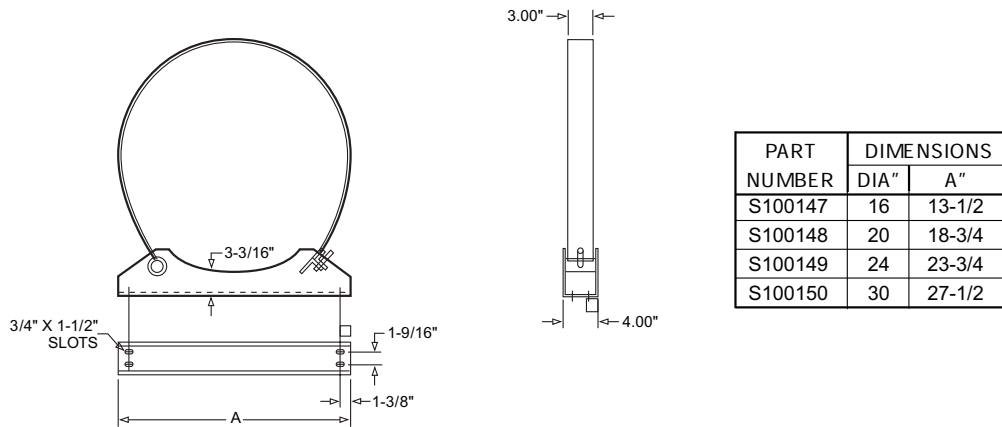

INDUSTRIAL HORIZONTAL AIR RECEIVERS WITH FEET ONLY

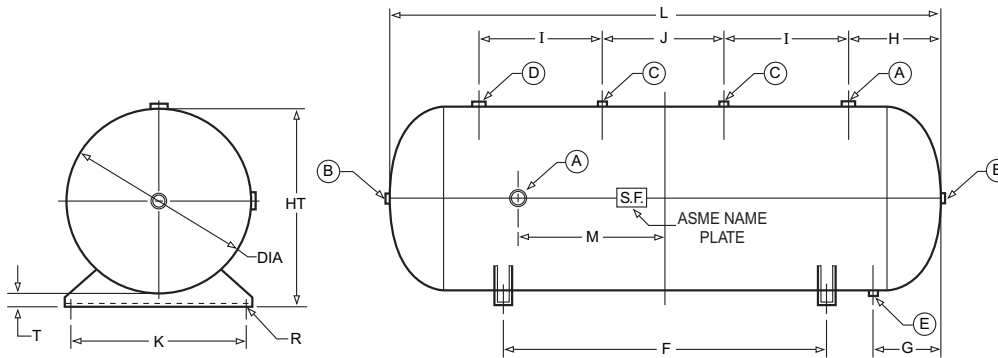

P/N	PSI	GAL	DIA	OPENINGS (NPT)"						DIMENSIONS "									
				L	A	B	C	D	E	F	G	H	I	J	K	R	M	HT	T
A10344	137	400	36	93	3	2	1/2	1-1/2	3/4	56	14	15	21	22	32	3/4	21	39	3
A10346	165																		
A10348	200																		
A10352	165	500	36	116	3	2	1/2	1-1/2	3/4	72	14	15	21	38	32	3/4	29	39	3
A10354	200																		

INDUSTRIAL HORIZONTAL AIR RECEIVERS

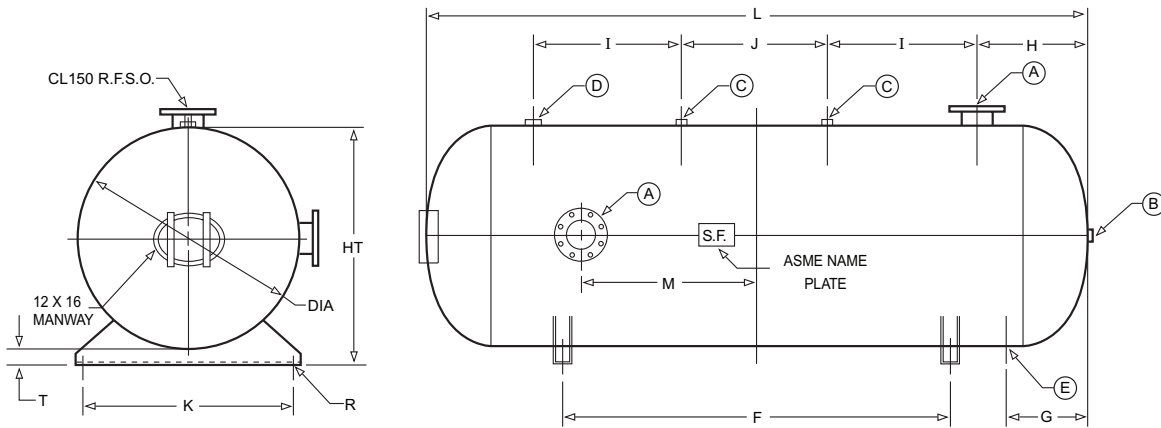

P/N	PSI	GAL	DIA	L	OPENINGS (NPT)"					DIMENSIONS "									
					A	B	C	D	E	F	G	H	I	J	K	R	M	HT	T
A10358	150	660	42	120	4	2	1/2	1-1/2	1	70	16	17	18	27	40	3/4	31	50	4
A10368	155	1060	48	144	6	2	1/2	2	1	84	18	24	32	32	44	3/4	38	56	4
A10370	137																		
A10376	137	1550	54	166	6	2	1/2	2	1	98	19	26	39	40	52	3/4	50	62	4
C102888	137	1350	54	148	6	2	1/2	2	1	80	19	26	33	30	52	3/4	41	62	4
C102889	165																		
A10376	137	1550	54	166															
C102890	150	1660	60	150	6	2	1/2	3	1	74	21	27	30	36	56	3/4	38	71	4
A10665	150	2000	60	174	6	2	1/2	3	1	98	21	27	39	40	56	3/4	50	68	4
A10392	150	2560	60	220	6	2	1/2	3	1	112	21	27	55	56	56	3/4	74	68	4
A10400	137	3000	66	214	6	2	1/2	3	1	110	23	29	52	56	56	3/4	71	74	4
A10402	125	3800	72	228	6	2	1/2	3	1	114	25	31	54	56	56	3/4	78	80	4
A10404	150																		
C101567	125	4500	78	235	6	2	1/2	3	1	114	26	34	54	56	58	3/4	82	88	4
C101568	150																		
C101569	125	5200	84	238	6	2	1/2	3	1	114	28	34	54	56	64	3/4	85	94	4
C101570	150																		
C101571	125	6000	90	241	6	2	1/2	3	1	114	30	36	54	56	70	3/4	88	100	4
C101572	150																		
C101573	125	7000	96	244	6	2	1/2	3	1	114	31	38	54	56	76	3/4	88	106	4
C101574	150																		
C101575	125	8000	102	247	6	2	1/2	3	1	114	33	40	54	56	82	3/4	90	112	4
C101576	150																		

VACUUM RECEIVERS

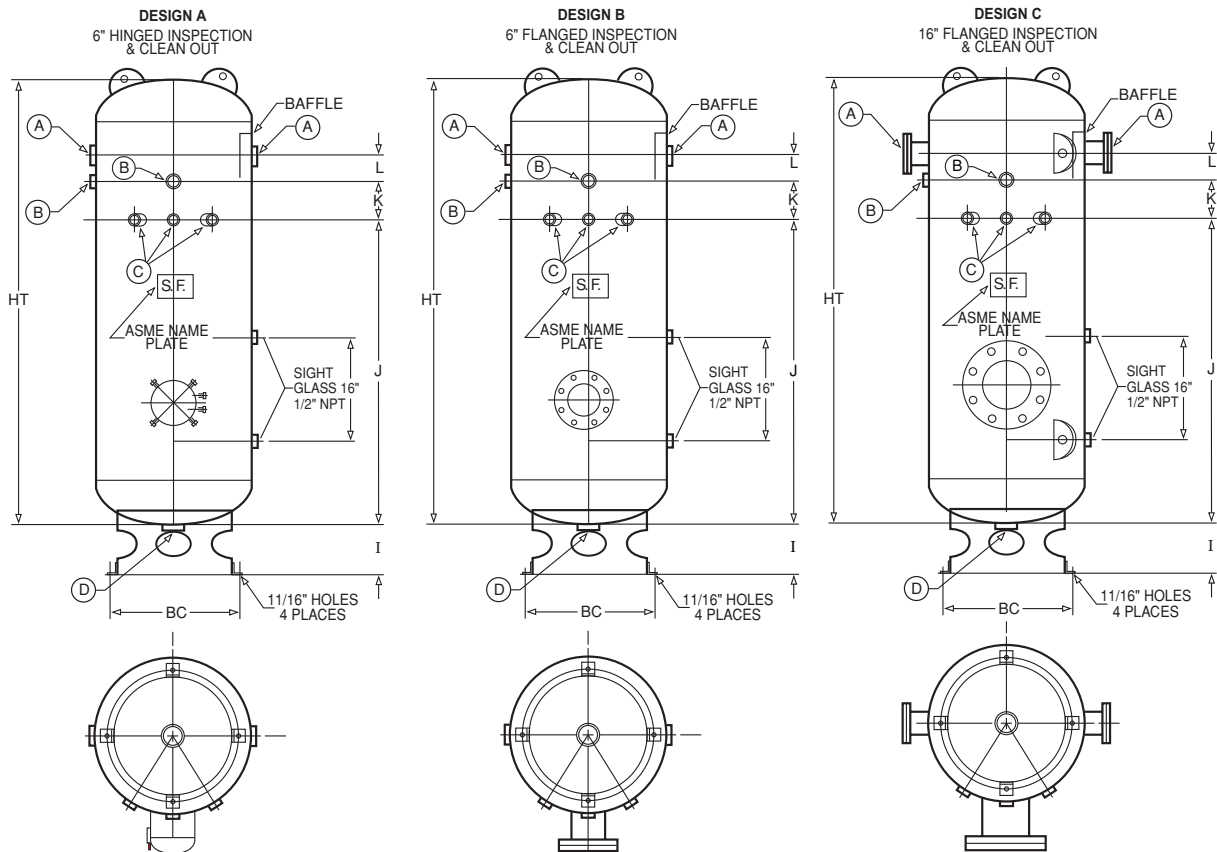

PART NUMBER		OPENINGS (NPT)"							DIMENSIONS "				
DESIGN A	DESIGN B	GAL	DIA	HT	A	B	C	D	I	J	K	L	BC
V10001*	V10011*	30	16	38	3	1	1/2	1-1/2	1-3/4	20	6	4	18-3/4
V10002*	V10012*	60	20	48	3	1	1/2	2	2-1/4	29	6	4	23-3/4
V10003	V10013	80	20	63	3	1	1/2	2	6	42	6	4	17
V10004	V10014	120	24	69	3	1	1/2	2	8	47	6	4	20
V10005	V10015	200	30	72	3	1	1/2	2	8	50	6	4	26
V10006	V10016	240	30	84	3	1	1/2	2	8	62	6	4	26
V10007	V10017	400	36	96	3	1	1/2	2	8	70	6	4	32
V10008	V10018	500	36	116	4	1	1/2	2	8	78	8	12	32

PART NUMBER		FLG	OPENINGS (NPT)"				DIMENSIONS "					
DESIGN C	GAL	DIA	HT	A	B	C	D	I	J	K	L	BC
V10019	660	42	120	6	1	1/2	2	8	78	8	14	38
V10020	1060	48	144	6	1	1/2	2	8	78	10	32	38
V10021	1550	54	166	6	1	1/2	2	8	78	10	52	44
V10022	2000	60	174	6	1	1/2	2	8	78	10	60	44
V10023	2560	60	220	8	1	1/2	2	8	78	10	106	44
V10024	3000	66	214	8	1	1/2	2	8	78	10	98	60
V10025	3800	72	228	8	1	1/2	2	8	78	10	110	58
V10026	4500	78	235	8	1	1/2	2	8	78	10	109	70
V10027	5200	84	238	8	1	1/2	2	8	78	10	110	78

- * These designs have 4 pressed steel feet.
- FLG = CL 150 Slip on flange (S.O.F.)
- 30 through 500 gallon vacuum receivers are available less clean out.