

Gardner Denver

SMALL DUAL TOWER DESICCANT AIR DRYERS

GDHM Series

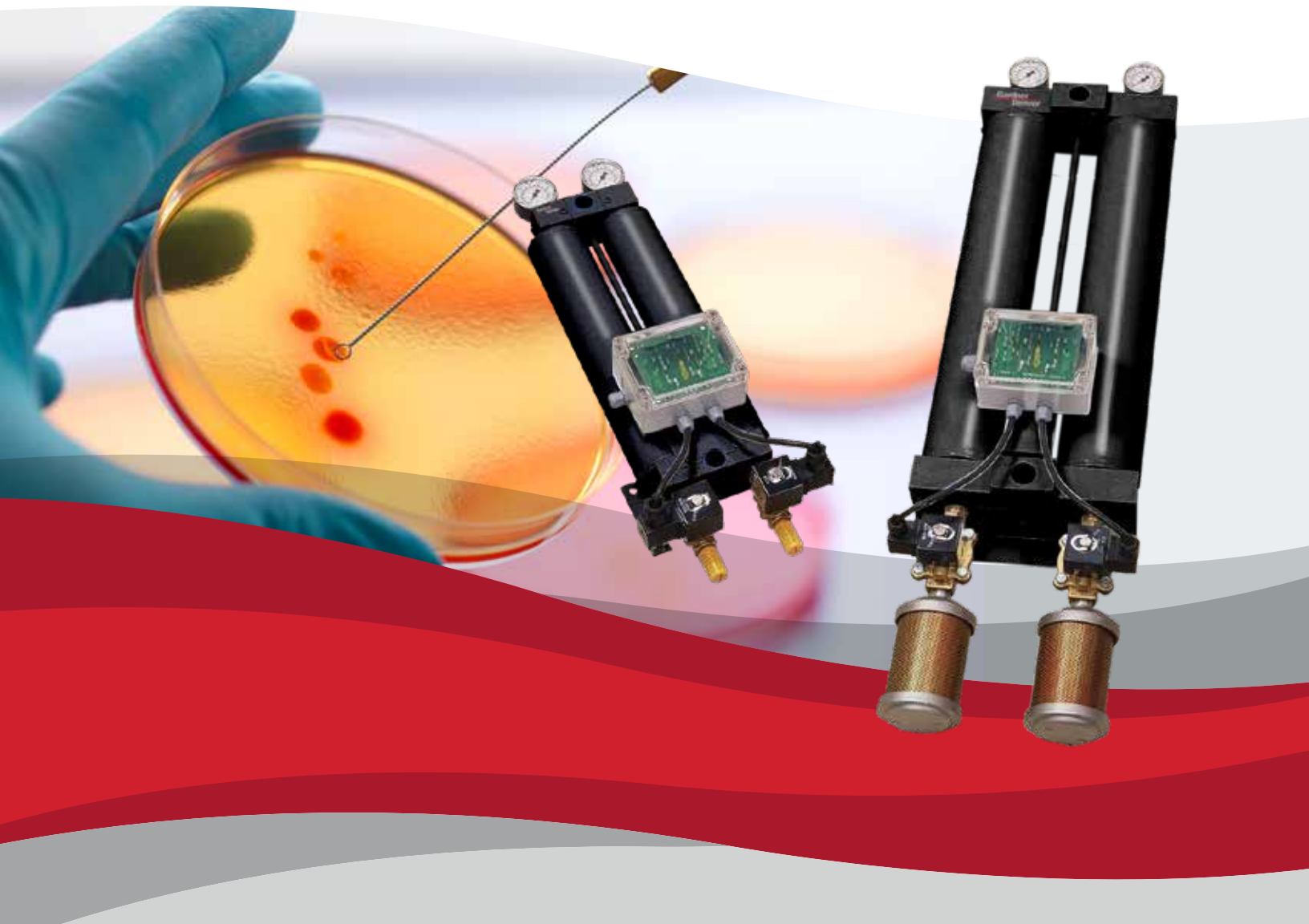

Dryer Operation

The GDHM Series Air Dryers use the proven “Pressure Swing Adsorption” (PSA) method for drying wet compressed air. This requires having two identical towers containing hygroscopic desiccant.

Incoming wet air enters the dryer through a shuttle valve where it is directed to the bottom of the tower containing dry desiccant. The desiccant in this tower removes 99.7+% of the water vapor from the air when operated at catalog conditions. The dried air leaving the top of the tower is directed to the outlet through a second shuttle valve. In this outlet shuttle valve a built-in orifice allows a portion of the dried air to flow into the other tower being regenerated. The orifice reduces the high pressure air down close to atmospheric pressure which lowers the dew point of the dried air even further.

The tower being regenerated/purged of moisture is connected to an energized solenoid valve for a controlled period of time. The electrical signal to the solenoid is monitored by an LED light on the solid state timer. After the desiccant is regenerated, the timer shuts off the power to the solenoid valve. Air continues to flow through the orifice to repressurize the regenerated tower to line pressure. The middle light on the timer indicates the repressurization function.

Next, the timer opens the valve on the tower containing the wet desiccant. This shifts the shuttle valve balls, and the tower with the wet desiccant is regenerated while the other tower continues to dry the air. Examining the flow schematic to the right demonstrates the air dryer process operation.

- Unique Energy Saving Design
- Can start and stop dryer with a compressor or point-of-use equipment to eliminate purge loss when off
- Solid State Memory starts dryer where it left off in drying cycle to prevent wet air downstream
- NEMA-4/4X & 3-Year Warranty

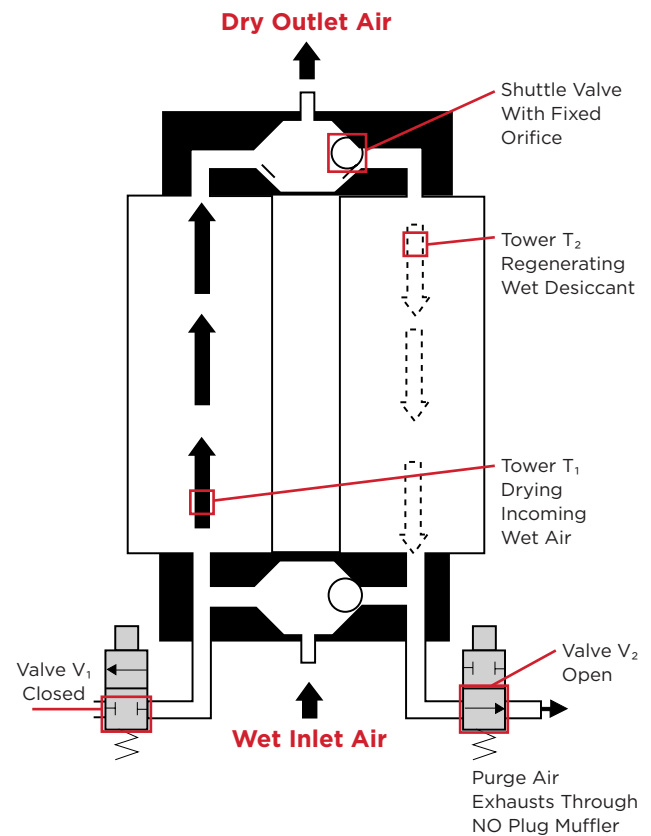

TIMING CYCLE

MODEL	TOTAL CYCLE	REGENERATING	REPRESSURIZING
GDHM3-12	90 Seconds with 45 Seconds Drying Per Tower	33 Seconds	12 Seconds
GDHM16-50	180 Seconds with 90 Seconds Drying Per Tower	66 Seconds	24 Seconds

Standard Design Features

- Solid state timer with LED display for visual monitoring
- Built in timer memory
- Low velocity air through the desiccant for more efficient drying
- Large internal air passages to reduce pressure drop
- NEMA 4 Components (protects against water spray and dust)
- Minimal threaded connections, for fewer leak points than competitive units
- Easy change out desiccant cartridges
- Components are all easily serviced and field replaceable (No special tools)
- Full repressurization before tower switch-over causes less shocking of the desiccant and no pressure fluctuation
- No Plug Mufflers (Will not rupture or reduce dryer efficiency)
- 6-Foot Electric Power Cord
- 3-Year Limited Warranty (parts only-excluding contaminated desiccant and solenoid wear parts)

Applications

- Electronic Chip Testing
- CNC Machine Tools
- Outdoor HVAC Controls
- Environmental Chambers
- Pollution Instrumentation
- Food Process Equipment
- Air Bearings
- Graphic Printers
- Air Turbines
- Vortex Tubers
- Car Wash Controls
- Spectrometers
- Air Brushing
- Gas Chromatographs
- Robotic Machinery
- Laboratory Analyzers
- Dry Sprinkler Systems
- Ozone Generators
- Air Operated Pumps

DIMENSIONS

MODEL	INCHES				*IN SCFM	OUT SCFM	WEIGHT LBS	IN/OUT NPT
	H	W	D	P				
GDHM3	13.8	7.3	5.3	8.4	3	2.2	8	3/8"
GDHM6	18.3	7.3	5.3	13	6	4.4	9	3/8"
GDHM9	17.3	7.3	5.3	12.0	9	6.6	10	3/8"
GDHM12	20.1	7.3	5.3	14.9	12	8.8	11	3/8"
GDHM16	33	9.5	6.6	20.7	16	12.6	29	1/2"
GDHM25	41.9	9.5	6.6	29.5	25	19.6	34	1/2"
GDHM35	39.3	10	7.1	33.4	35	27.4	59	1/2"
GDHM50	46.3	10	7.1	33.4	50	39.2	65	1/2"

*Standard flows (SCFM) at 100 psig and 100°F inlet with -40°F pressure dew point. Consult factory for -100°F dew point and performance at other inlet pressures (50-150 psi), or inlet temperatures above 100°F.

Correction Factors: 125 psi = 1.22, 150 psi = 1.44

Note: Inlet and outlet filtration required for proper dryer performance.

Specifications

Voltage:	115/1/50/60 or 230/1/50/60
Maximum Inlet Temperature:	120° F
Minimum Ambient Temperature:	32° F
Maximum Inlet Pressure:	150 psig
Inlet Filtration Recommended:	5 micron and .01 micron (Coalescing)
Inlet Filtration Required:	.01 micron (Coalescing)
Outlet Filtration Recommended:	1 micron (Particulate)

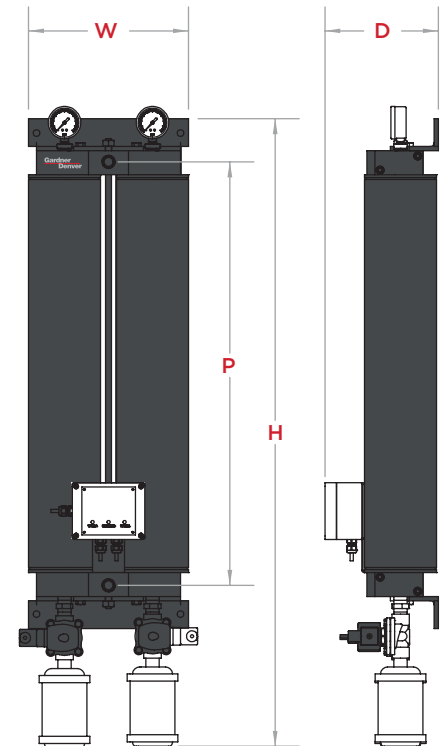

Shown with optional tower pressure gauges

The leader in every market we serve
by continuously improving all business processes
with a focus on innovation and velocity

**Gardner
Denver**[®]

Gardner Denver, Inc.

1800 Gardner Expressway
Quincy, IL 62305
866-440-6241

www.gardnerdenver.com/gdproducts



©2019 Gardner Denver, Inc. Printed in U.S.A.
GA-GDHM 2nd Ed. 10/19

