

REVISION HISTORY						
ZONE	REV	DESCRIPTION	ECN #	DATE	DWN	CHK
	02	REMOVED LIFTING LUGS	1114643	30-Jan-18	rn8465	

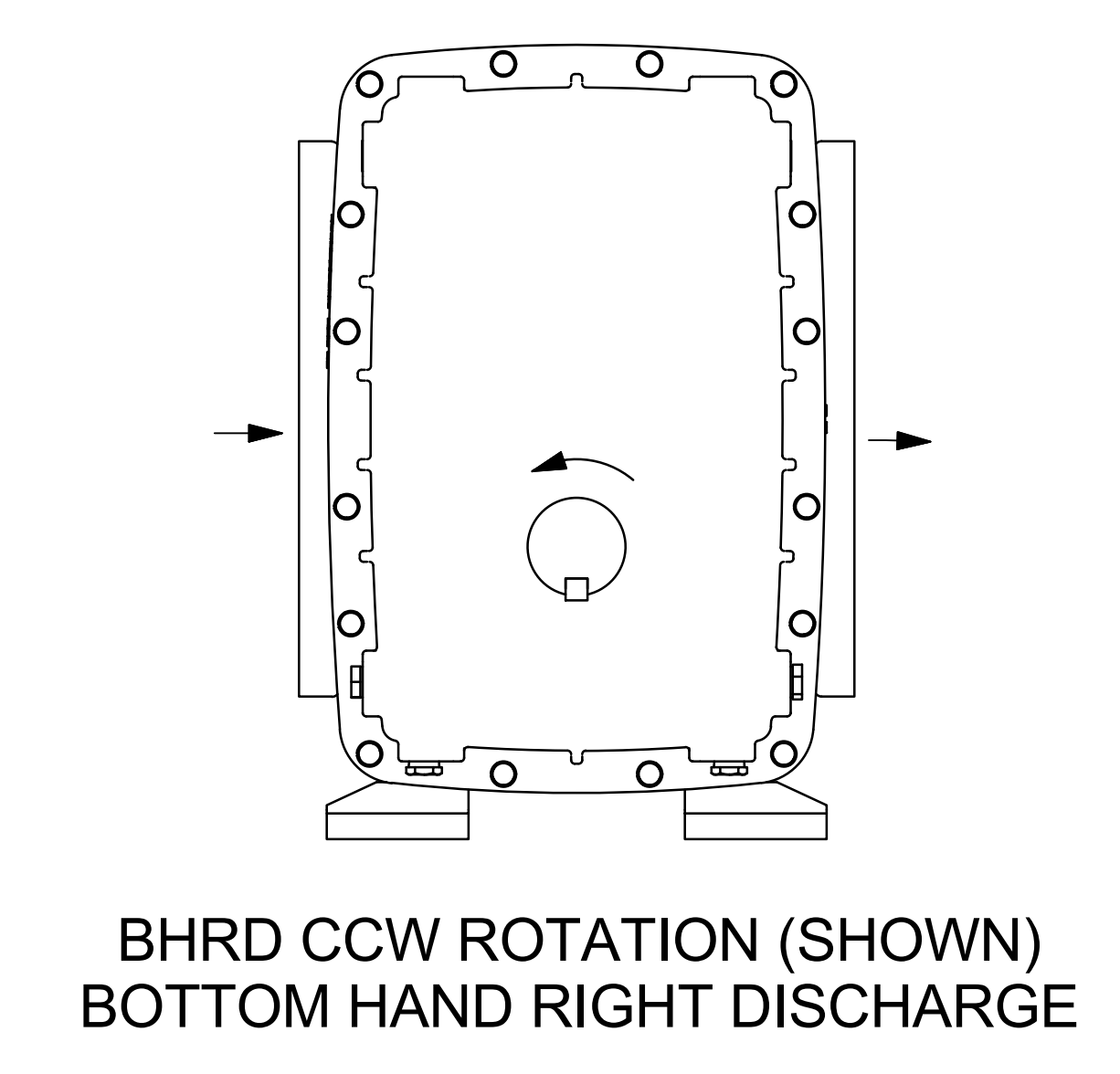
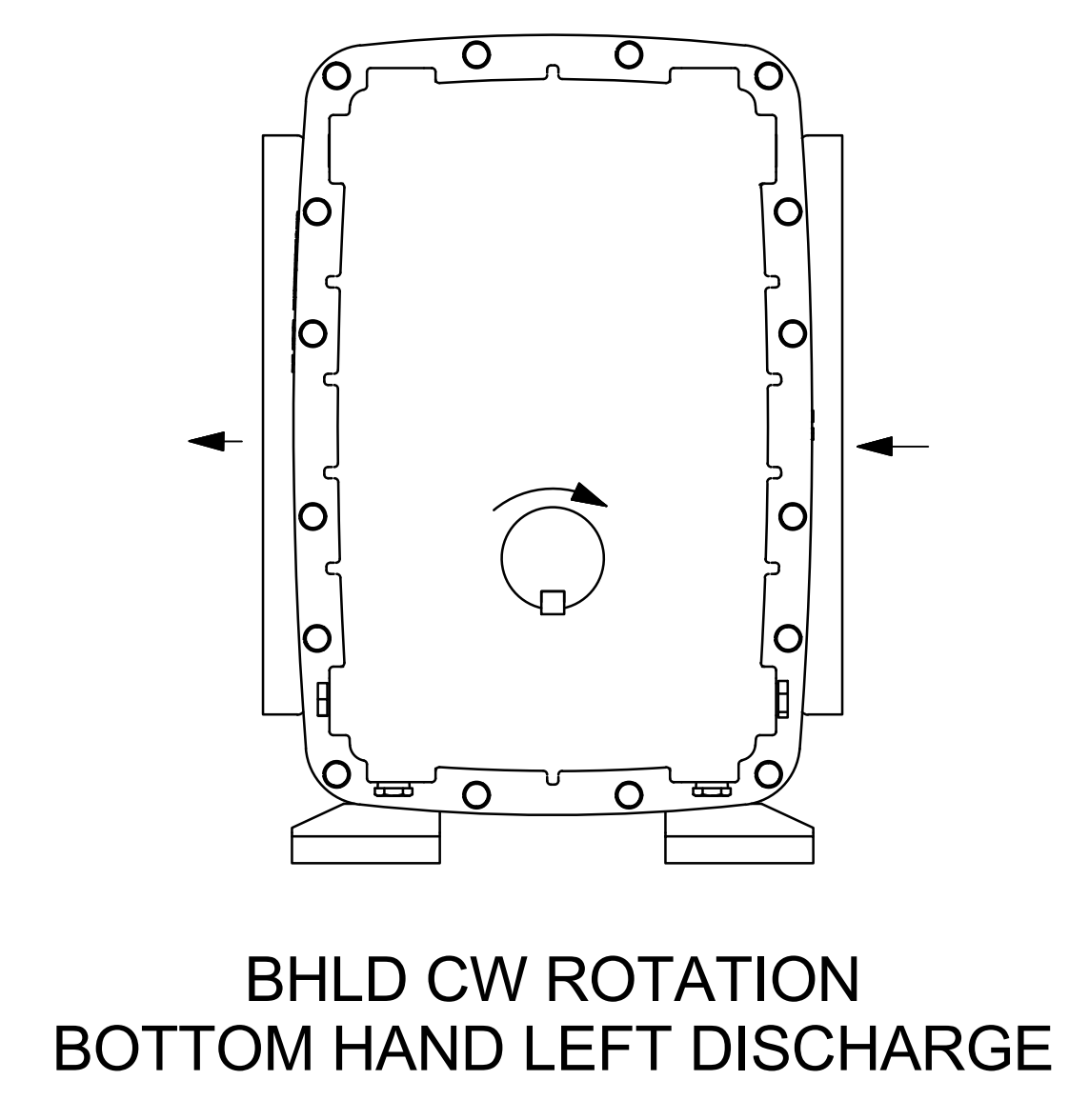
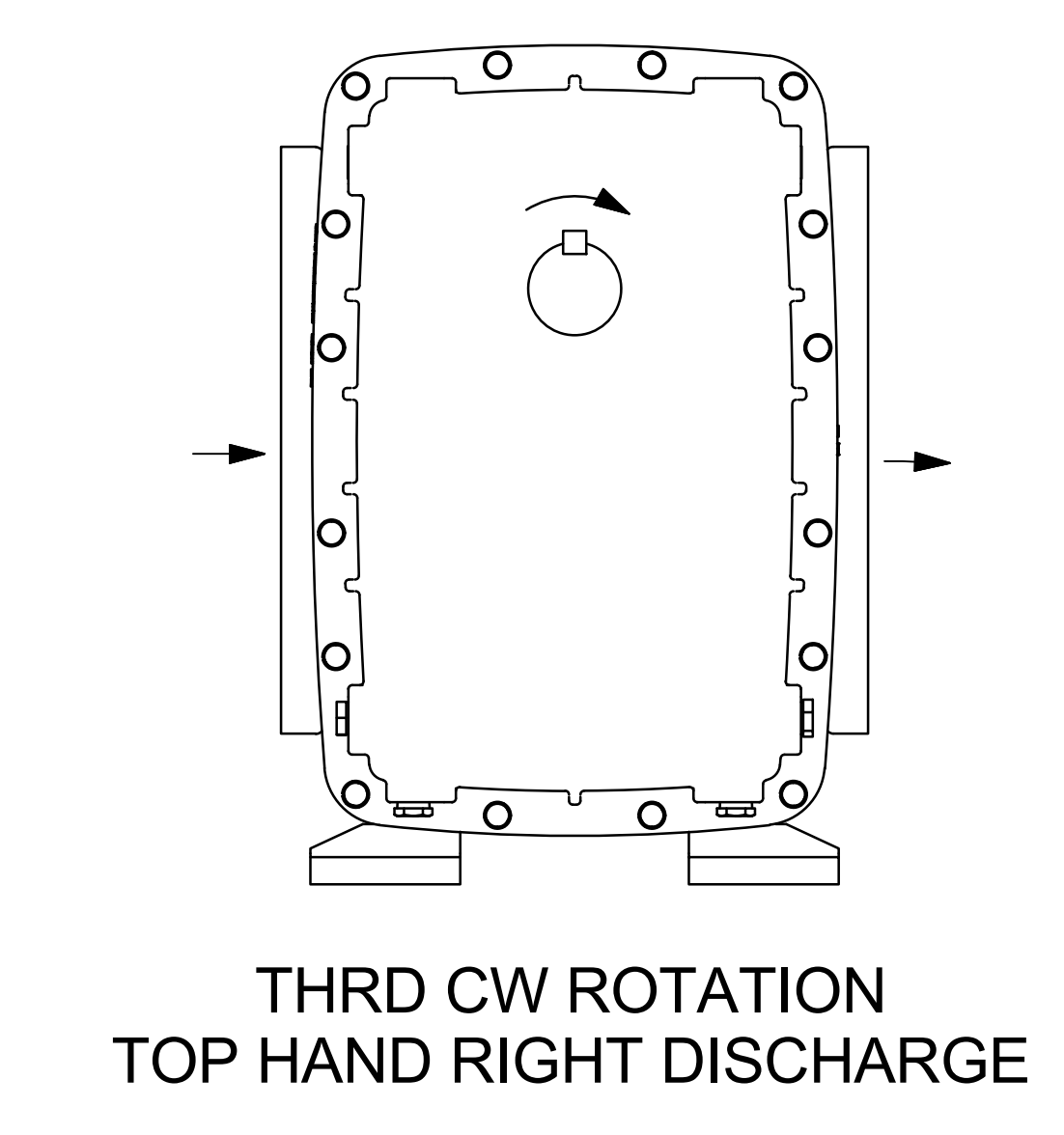
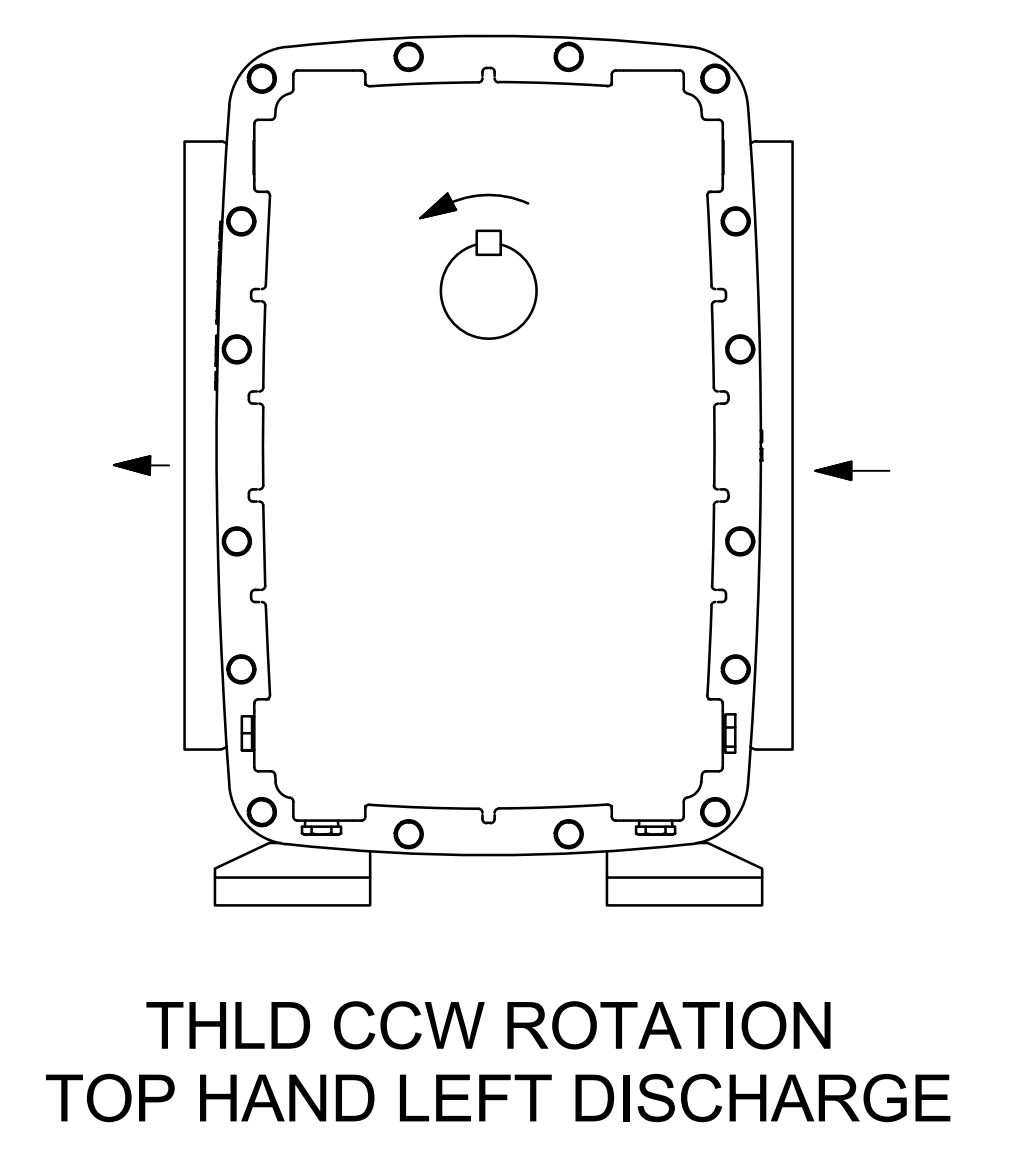
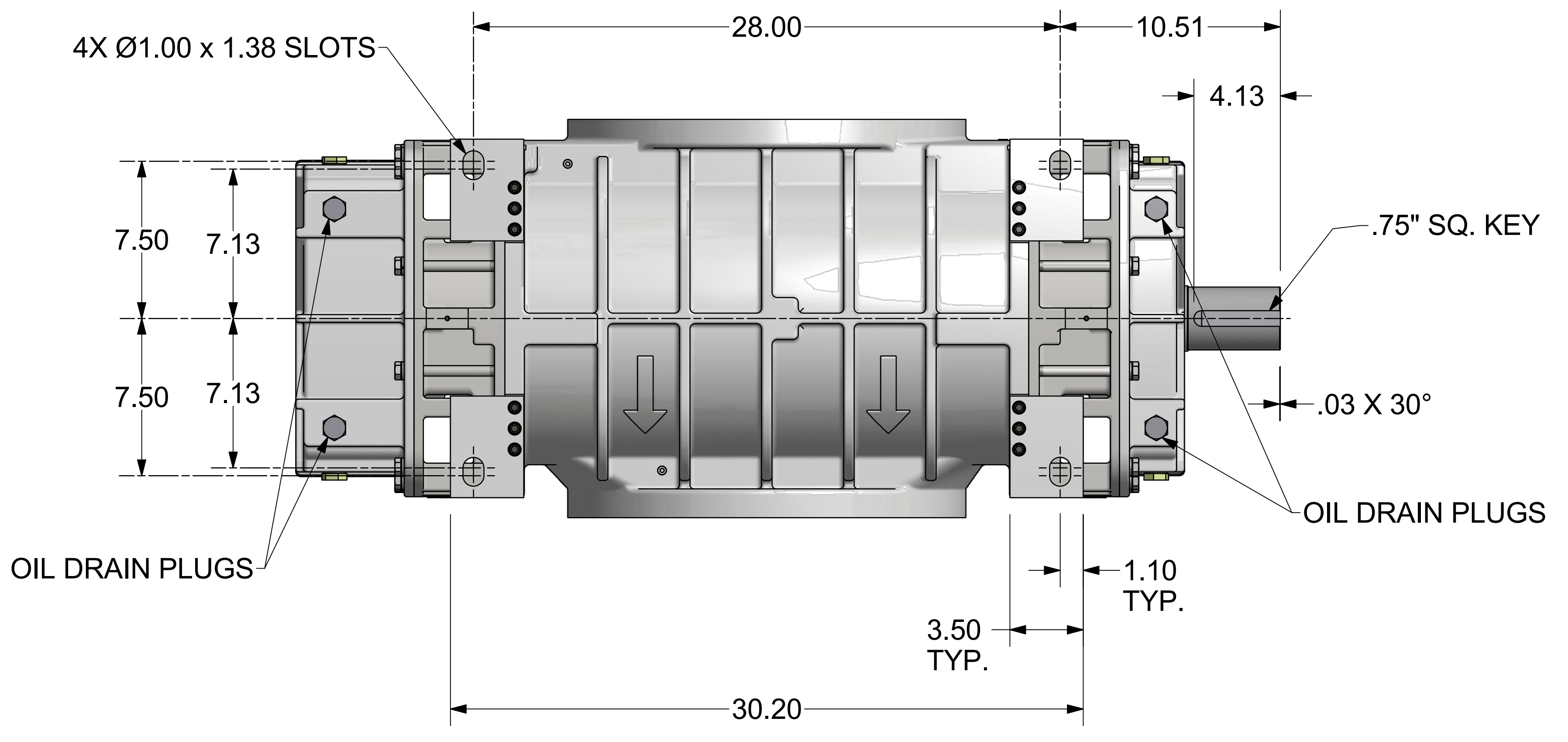
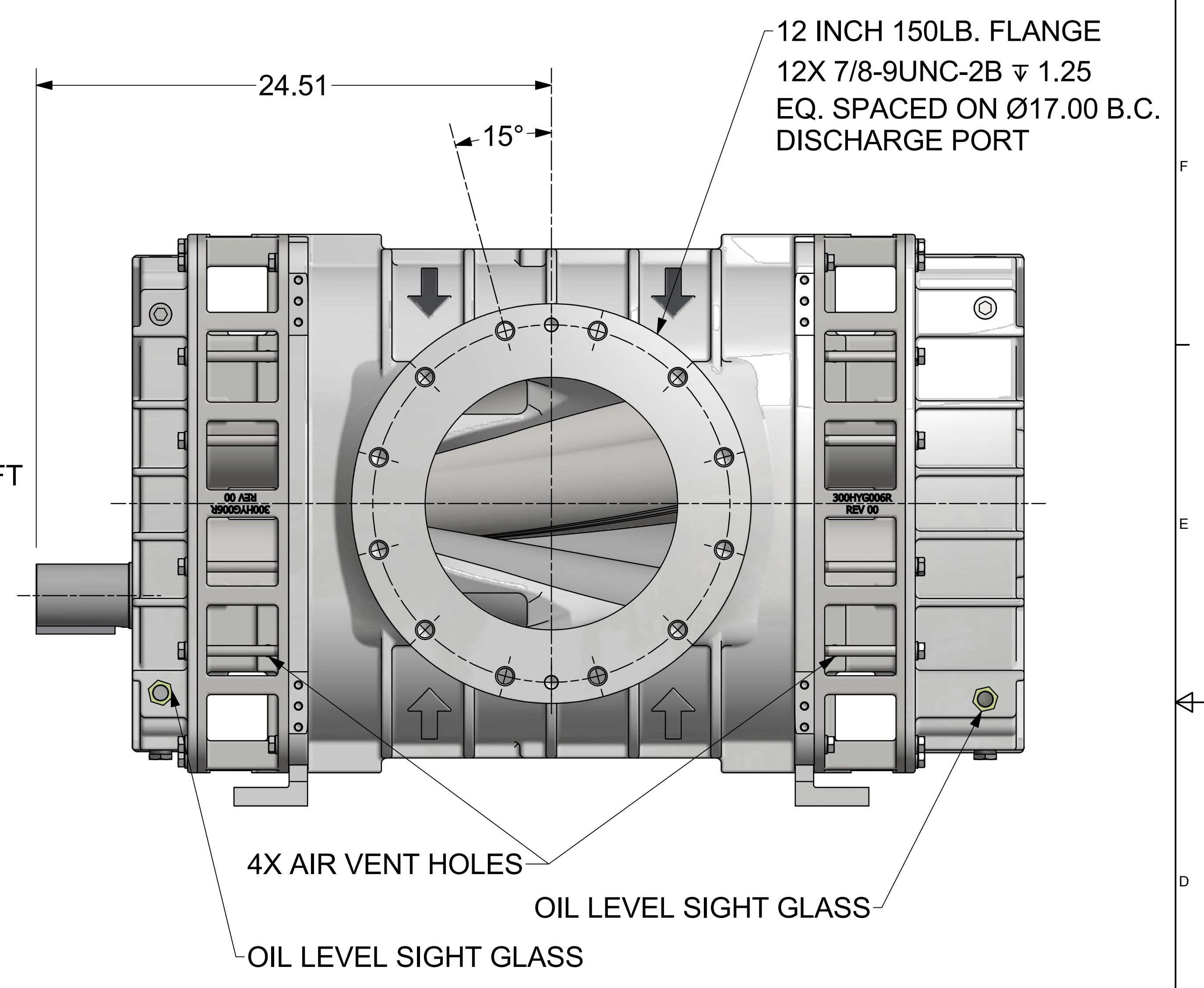
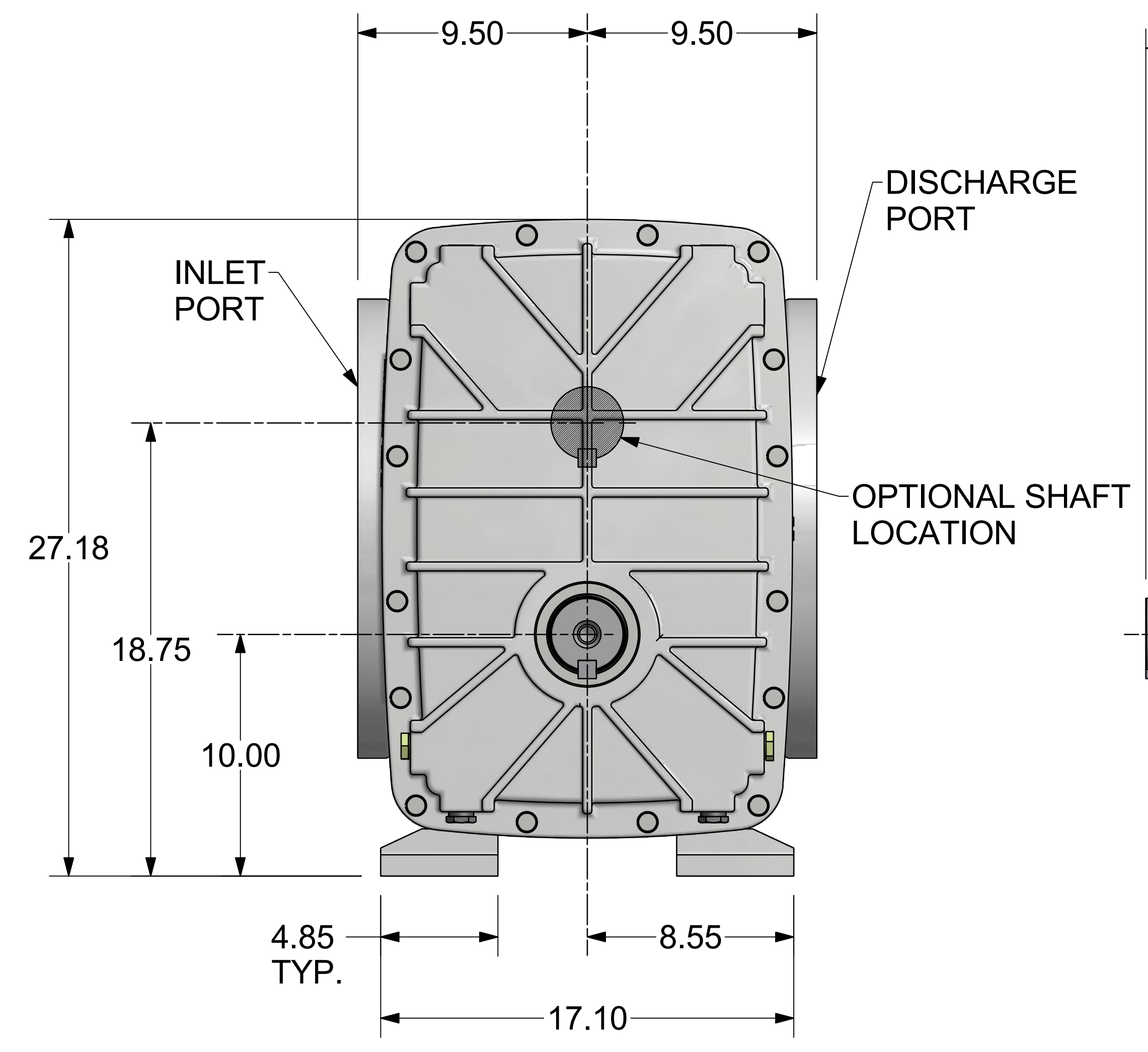
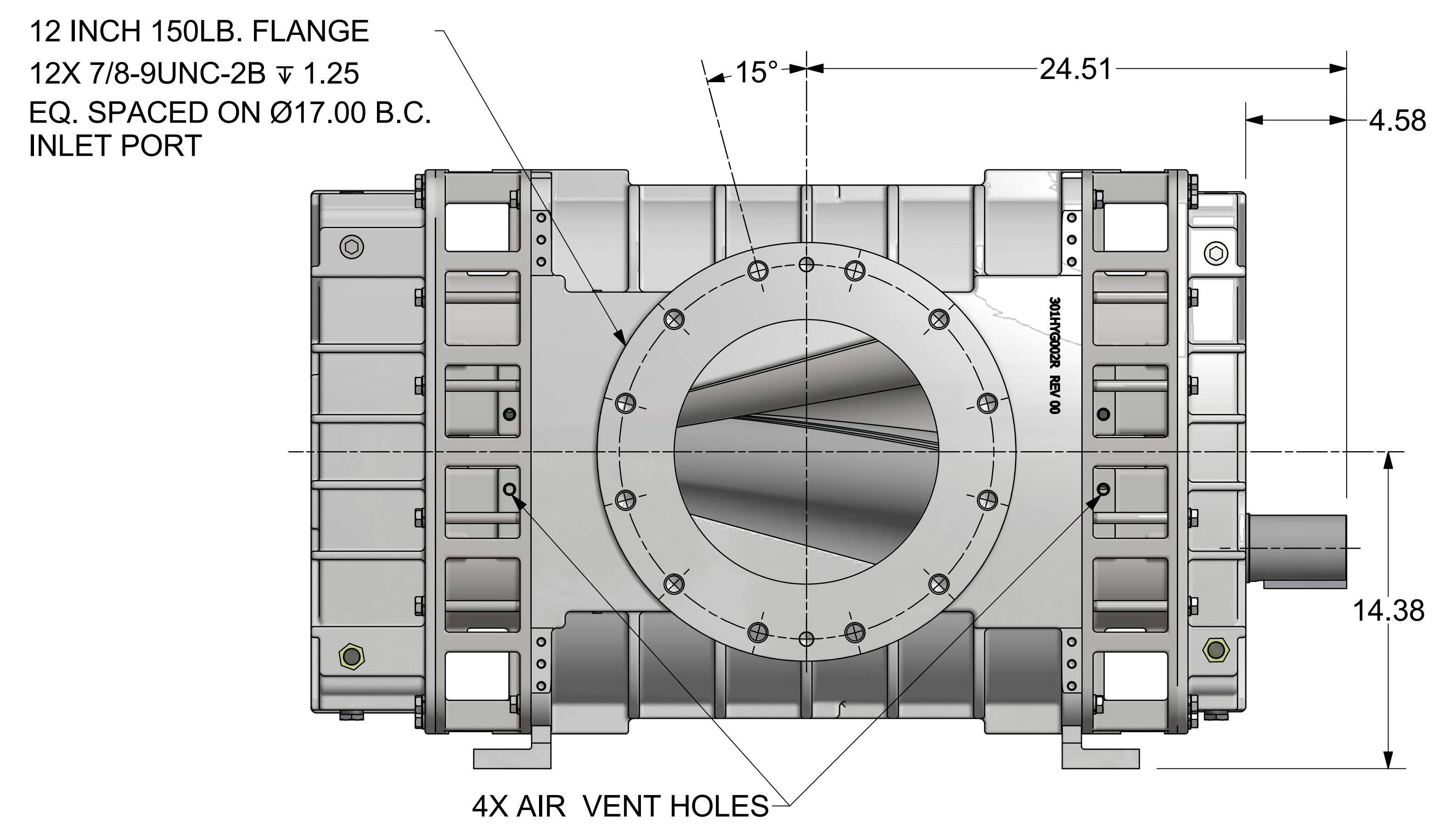
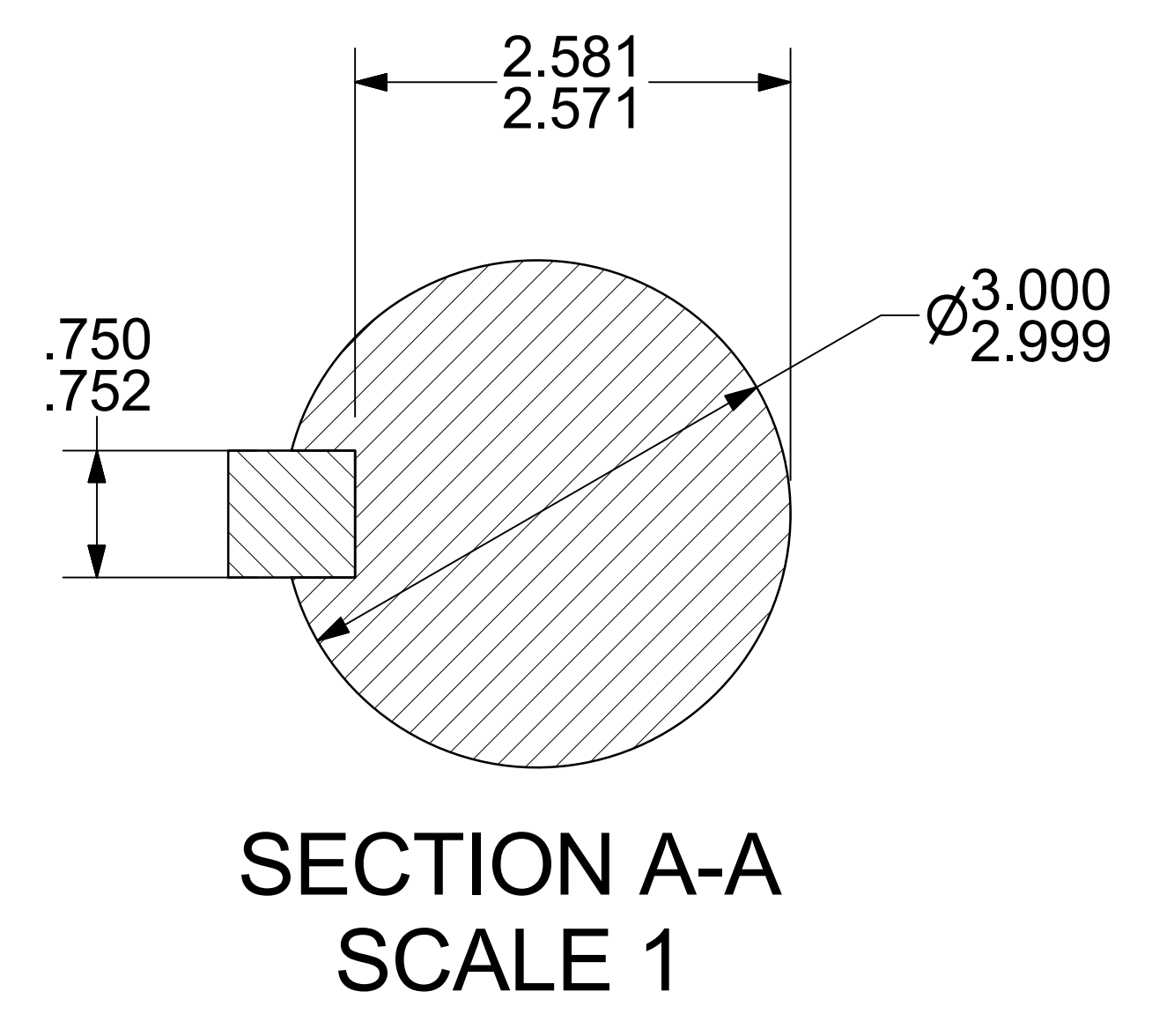
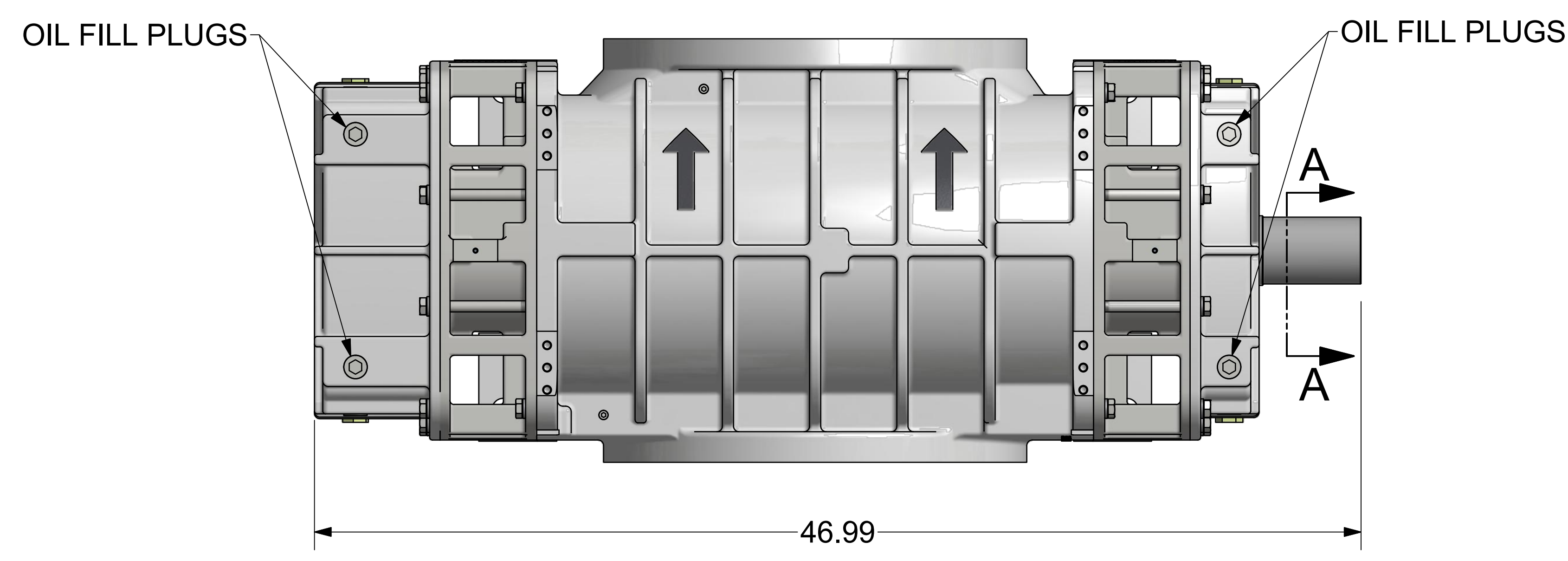

FINISH OF CHAMFERS AND FILLETS TO CONFORM TO SURFACE ROUGHNESS MAXIMUM PER ASME B46.1. FULL THREAD DEPTHS ARE MINIMUM.

UNLESS OTHERWISE SPECIFIED DIMENSIONS ARE IN INCHES

TOL. ON DECIMALS: X = \pm .05
TOL. ON DECIMALS: XX = \pm .02
TOL. ON DECIMALS: XXX = \pm AS SPECIFIED
TOL. ON ANGLES: = \pm 0'-30'

THIRD ANGLE PROJECTION

CONFIDENTIAL - THE INFORMATION CONTAINED IN THIS DOCUMENT IS THE PROPERTY OF GARDNER DENVER, INC. IT IS NOT FOR PUBLIC DISCLOSURE. POSSESSION OF THE INFORMATION DOES NOT CONVEY ANY RIGHT TO LOAN, SELL, OR DISCLOSE THE INFORMATION. UNAUTHORIZED REPRODUCTION OR USE OF THE INFORMATION IS PROHIBITED. THIS DOCUMENT IS TO BE RETURNED TO GARDNER DENVER, INC. UPON THE COMPLETION OF THE PURPOSE FOR WHICH IT IS LOANED OR UPON REQUEST.

DIMENSIONING AND TOLERANCING PER ASME Y14.5-2009
THREADS PER ASME B1.1 GAGING SYSTEM 21 U.O.S., ANSI B1.20.1 & B1.20.3

HEAT TREATMENT

Gardner Denver
Gardner Denver Inc.
Quincy, IL

DESCRIPTION: 4093-GRP-BLOWER
HELIFLOW 825 VERTICAL

DRAWN BY: pmc2275
CHECKED BY: rn8465

DATE: 28-Aug-17
SCALE: 1/4

ENGR. APPROVAL: pmc2275
DATE: 14-Sep-17

DWG. NO.: 302HYG800
SHEET: 1 OF 1

REV: 02