

Gardner
Denver

POSITIVE DISPLACEMENT BLOWERS & VACUUM PUMPS

HeliFlow[®]
Industrial Series



It's all about...

the HeliFlow

The HeliFlow Series integrates proven experience with blower design and manufacturing techniques to create an innovative helical tri-lobe blower. Gardner Denver has created a low noise solution for positive displacement blower and vacuum pump applications.

BACKED BY A
2 YEAR
WARRANTY

From date of initial use or
30 months from date of shipment

HELIFLOW DELIVERS

- Pressure to 15 psig
- Vacuum to 17 inHg
- Airflow to 4800 cfm



4" MODELS
406, 408, 412



5" MODEL
514

Results

Durability

Innovation

Trust

QUIET

Tradition

Strength

Quality

Efficiency

Performance



6" MODELS
616, 624

8" MODEL
825

It's all about...

the Savings



RUGGED CONSTRUCTION

Reduces maintenance and downtime



GREATER EFFICIENCY

Lowers operating costs



QUIETER OPERATION



Reduces enclosure and hearing protection requirements

Lower Cost + Higher Revenue
SAVES MONEY



**HIGHER
REVENUE**



PERFORMANCE

Higher pressure, vacuum
and temperature limits

It's all about...

the PULSE

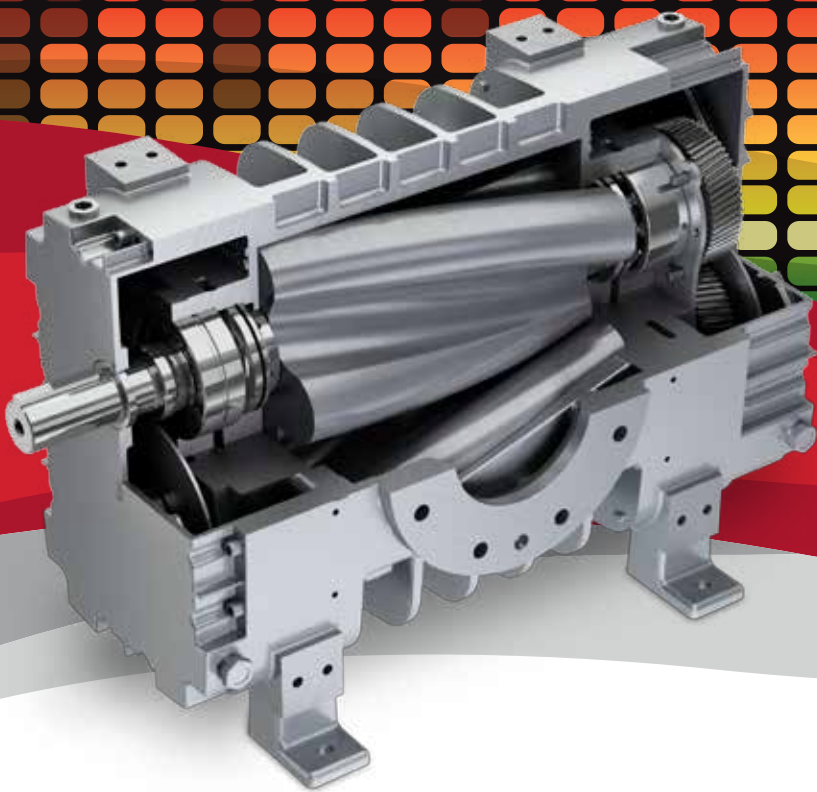

REDUCES NOISE LEVELS

Up to 4-7 dBA

Protect your ears,
Protect your **WORKFORCE**

Noise Levels dBA

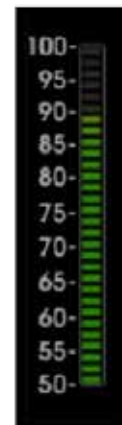

HeliFlow

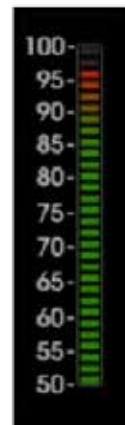

Typical
Lobe Blower





CHANGE IN PRESSURE PULSE

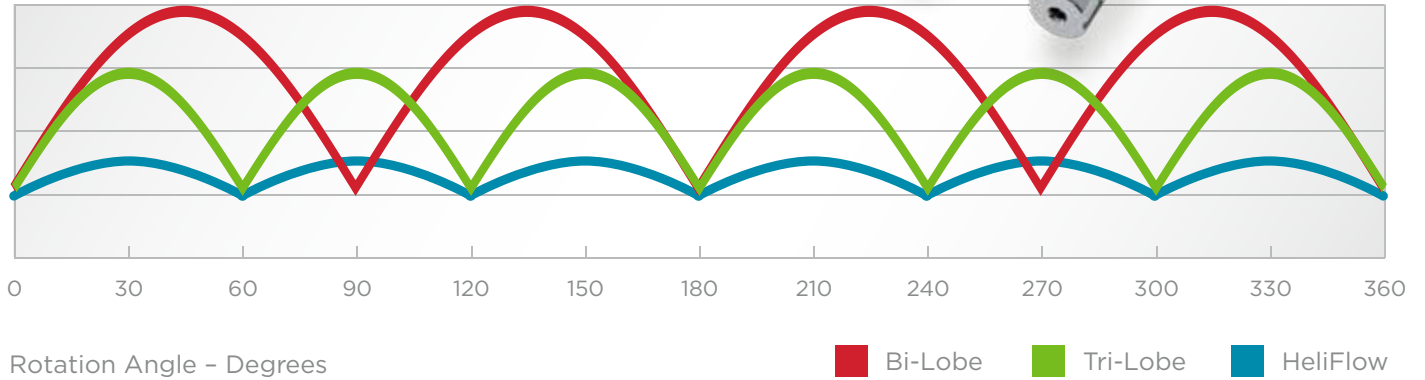

The HeliFlow Series

REDUCED PULSE = LOWER NOISE = QUIETER OPERATION

Lower Noise

Discharge pulsation is the chief contributor to high noise levels. HeliFlow provides the lowest pressure pulse in the lobe blower market. This reduces noise levels by 4-7 dBA over similar sized, straight-lobe blowers.

Reduced Pulsations

HeliFlow provides more consistent flow variation, reducing the potential for damage to downstream valves and instrumentation.

Higher Reliability

Discharge pressure pulsation causes axial thrust and higher variations in torque resulting in reduced bearing life. The HeliFlow smooth pulse operation extends the life of the blower.

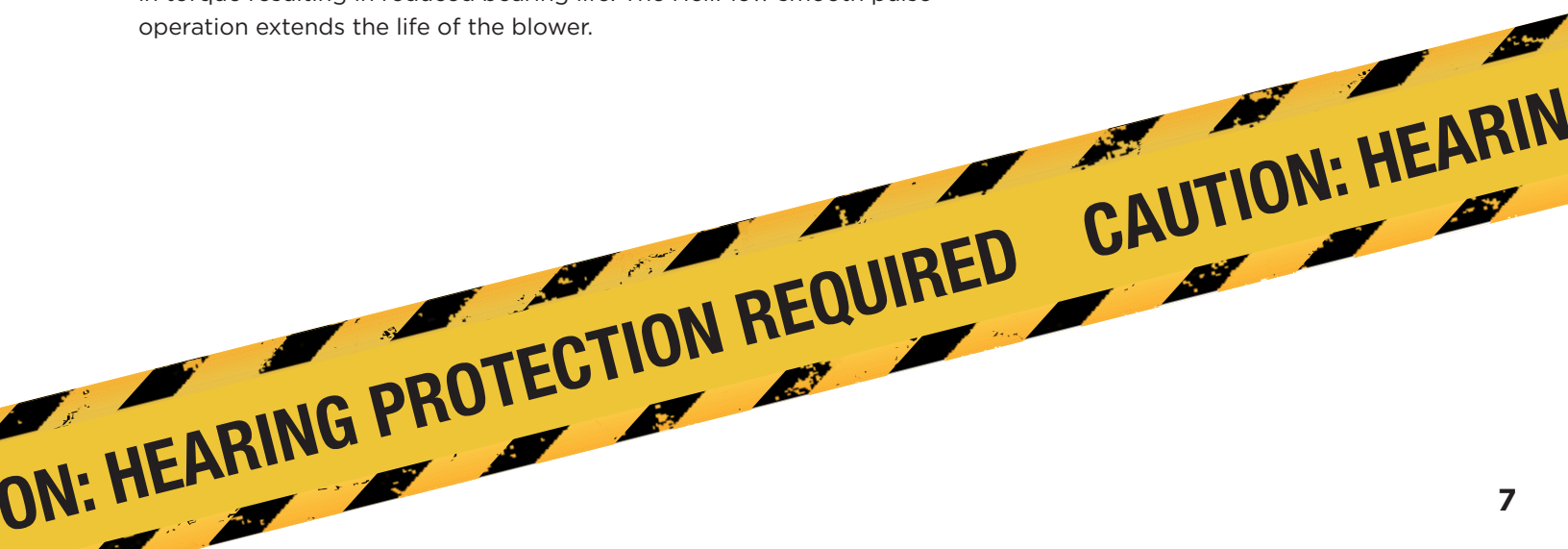

It's all about...

an Innovative Design

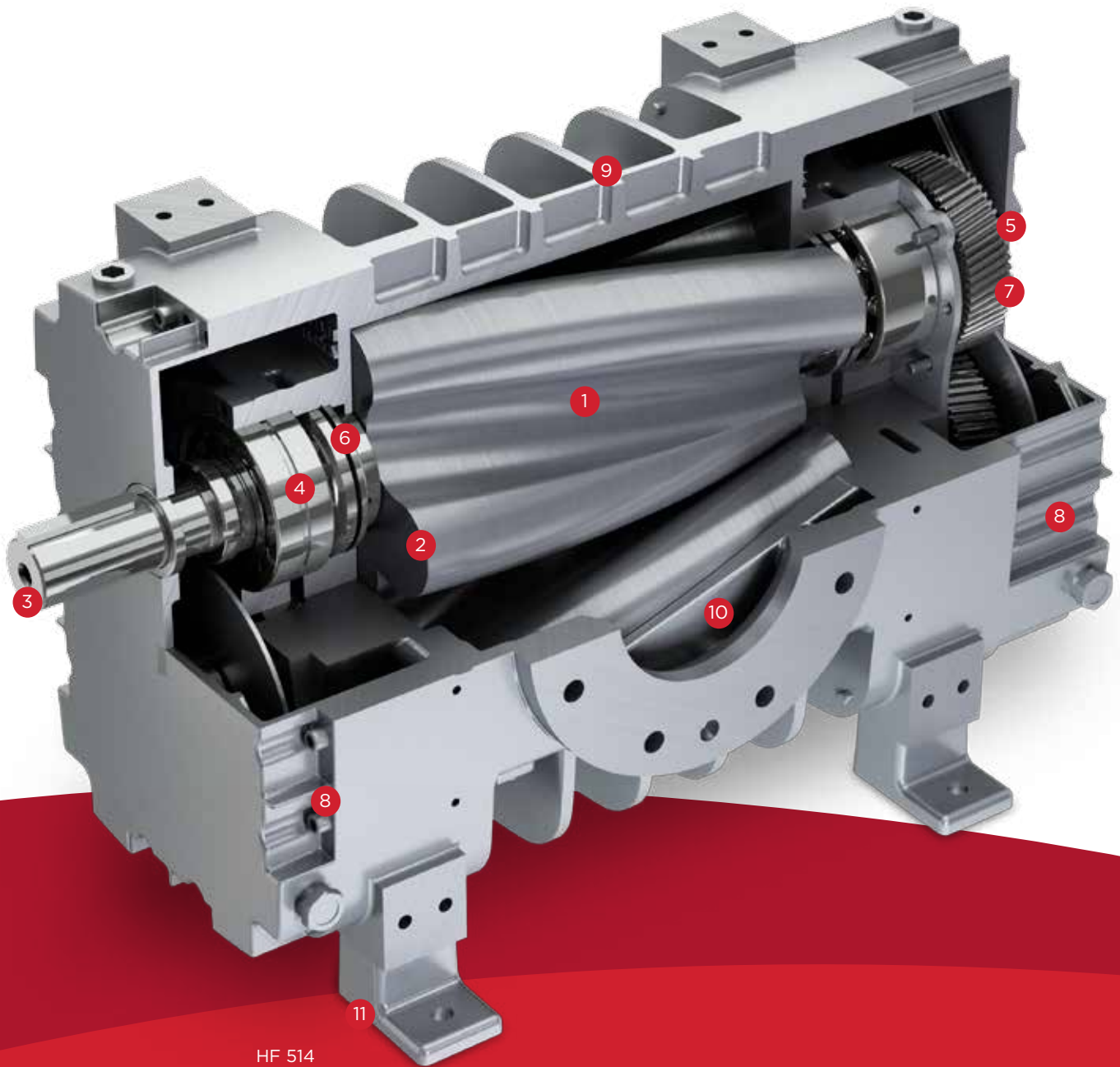

HeliFlow Design Advantages

1 Innovative, proprietary, smooth-running, helical rotor profile significantly reduces pulsations and discharge noise levels for quieter operation



2 Solid rotor design eliminates the potential for vibration caused when hollow rotors become unbalanced due to build-up of ingested material inside the rotor cavities

- Rotors and shafts are machined from high-strength ductile iron and are dynamically balanced to ISO Grade 6.3 as standard

3 Large diameter shafts provide superior overhung load capacity compared to competitive models

4 Oversized spherical roller bearings for superior reliability

- Precision fit bearings mounted on large diameter shafts provide longer blower service life



5 Refined timing and gear locking device

- Grip rings expand against the bore of the gear and compress on the shaft for a secure, mechanical shrink fit

- 8" model uses tapered press fit gears



6 Advanced piston ring oil and air seals provide leak-free operation

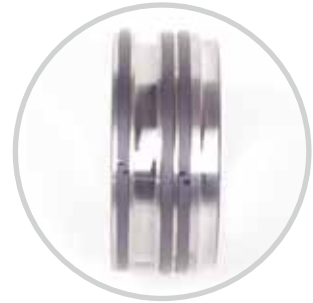

- 1 air and 2 oil seals

- 2 air and 2 oil seals (8" model)

7 Helical alloy steel timing gears provide quiet and smooth mechanical operation at all speeds



8 Dual splash lubrication for reduced maintenance intervals and superior durability

9 The single piece cylinder incorporates large external fins for heat dissipation and structural integrity

10 The unique triangular tuned ports and extra cylinder mass provides greater strength and noise attenuation

11 Flexible design allows mounting feet to be attached inward or outward based on installation requirements (not available on 8" model)

- Offers the ability to connect units in a variety of configurations

Raising the Bar with Cutting Edge Technology

It's all about...

the Advantages

PRODUCT DESIGN	HELIFLOW 514/616/624/624/825	COMPETITOR A	COMPETITOR B	HELIFLOW ADVANTAGES
CYLINDER & RIB DESIGN	One piece with integral ribs	One piece without ribs	One piece without ribs	<ul style="list-style-type: none"> Noise & pulsation dampening Improves heat dissipation Reduces stress on cylinder Ensures better tip clearance accuracy
DRIVE & GEAR END BEARINGS	Spherical roller	Cylindrical roller (drive) Double row ball (gear)	Cylindrical roller	<ul style="list-style-type: none"> Increases bearing life Better equipped to handle radial & axial loads commonly caused by misaligned V-belt drives
GEAR TYPE	Helical	Helical	Spur	<ul style="list-style-type: none"> Quiet & smooth mechanical operation Reduces backlash Allows tighter clearances
GEAR ATTACHMENTS	Grip rings Press fit gears (825)	Keyed interference fit	Taper gear fit	<ul style="list-style-type: none"> Improves reliability & eliminates timing loss Easier to rebuild Easily adjustable & release-able mechanical shrink fit
ROTOR PROFILE	Solid, Helical Tri-Lobe	Hollow, Dual-Lobe	Hollow, Dual-Lobe	<ul style="list-style-type: none"> Reduces noise & pulsations Improves blower life Eliminates the potential for unbalanced rotors due to product contamination
OIL SEALS	Two piston ring seals with slinger & groove	Lip seal	Lip seal	<ul style="list-style-type: none"> Superior oil sealing Dependable supply of oil-free air Extends maintenance intervals

PRODUCT DESIGN	HELIFLOW 514/616/624/624/825	COMPETITOR A	COMPETITOR B	HELIFLOW ADVANTAGES
MAX. OVERHUNG LIMIT (IN-LBS)	514 = 8100 616/624 = 13500 825 = 19,500	3200 <7999 18,000	1600 <7999 NA	<ul style="list-style-type: none"> More resistant to overhung loads Will not require a jack shaft at higher HP
PRESSURE CAPABILITY (PSIG)	514 = 15 624 = 12 825 = 15	10 10 15	13 10 NA	<ul style="list-style-type: none"> Increased pressure capability
TEMPERATURE RISE LIMITS (°F)	624 = 250 825 = 265	230 230	230 NA	<ul style="list-style-type: none"> Improved ability to withstand extreme operating conditions
APPROXIMATE WEIGHT (LBS)	514 = 667 616 = 865 624 = 1145 825 = 1,820	410 650 775 1,330	615 650 775 NA	<ul style="list-style-type: none"> Extra cylinder mass for reduced noise & pulsations More robust design



It's all about...

the Applications



THE HELIFLOW PROVIDES REVOLUTIONARY

Sound Levels | Durability | Performance

Ideal Applications:

- Wastewater
- Carpet Cleaning
- Pneumatic Conveying
- Milling
- Plastics ...and MANY more!



406 & 408 Dimensional Data

MODEL	WEIGHT	SHAFT DIAM.	A	B	C	D	E	F	G	H	J	K	L	M	N	P	Q
HF 406	173	1.25	13.0	6.5	6.0	16.27	5.5	4.71	2.36	6.53	2.8	8.66	5.39	9.76	4.33	4.5	0.25 × 0.25 × 2.0
HF 408	201	1.25	13.0	6.5	6.0	18.77	7.94	7.21	3.61	6.53	2.8	8.66	6.36	9.76	4.33	4.5	0.25 × 0.25 × 2.0

Dimensions shown in inches. Weights are in pounds and approximate (packaging materials included). Dimensions for installation purposes provided upon request.
 406 = 3" NPT, 408 = 4" NPT & 412 = 6" Flange; Mounting holes 3/8-16 UNC

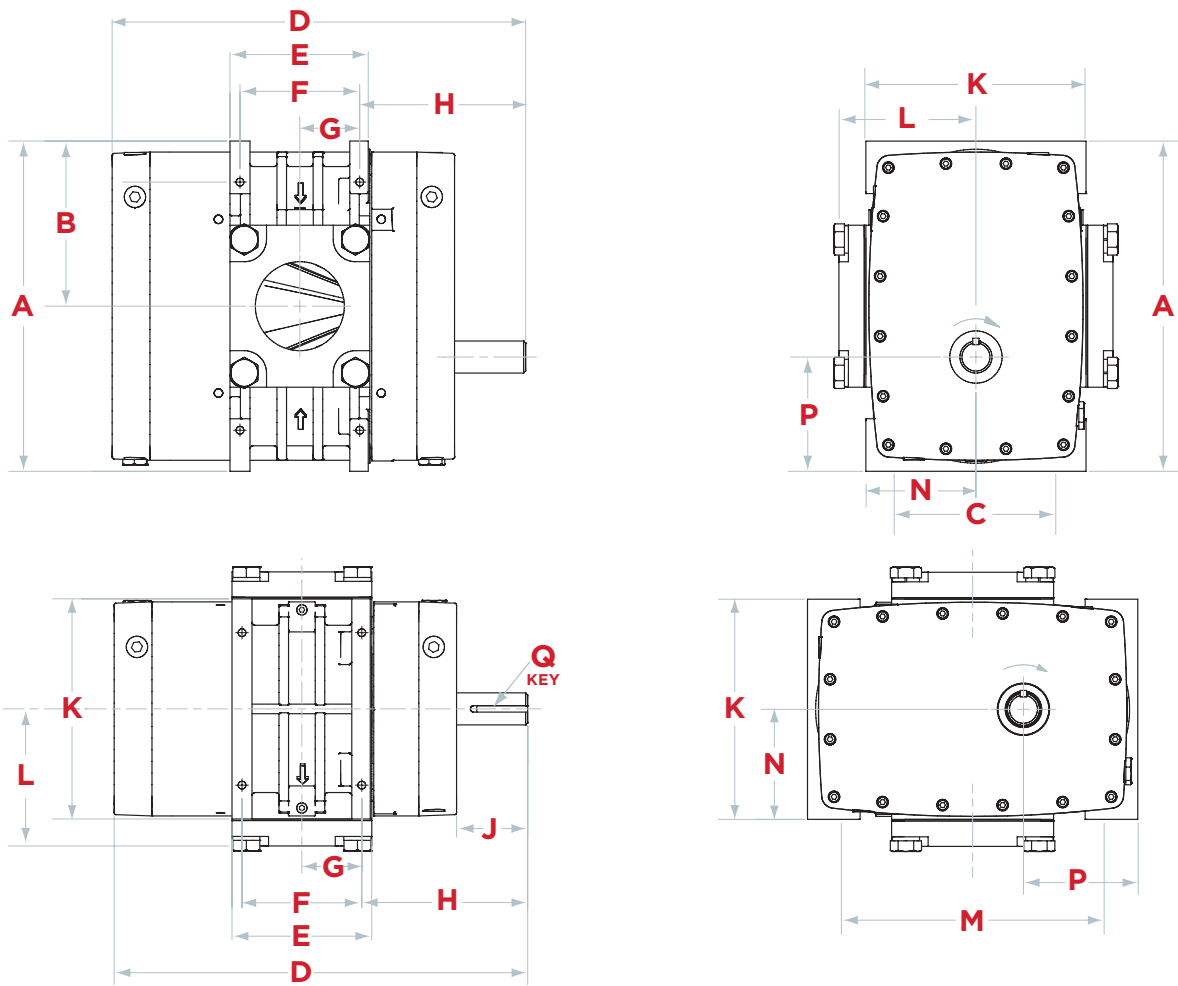

406 & 408 Performance Data

PRESSURE

MODEL	RPM	5 PSI		7 PSI		10 PSI		12 PSI		15 PSI	
		CFM	BHP	CFM	BHP	CFM	BHP	CFM	BHP	CFM	BHP
HF 406	1760	147	4.7	136	6.4	120	9.0	111	10.8		
	2190	198	6.0	187	8.2	171	11.5	161	13.8		
	2620	248	7.6	236	10.3	220	14.3	211	17.0	198	21.0
	3600	357	12.0	345	15.7	328	21.3	318	25.1	305	30.7
	4000	399	14.2	387	18.3	370	24.5	360	28.7	346	35.0
HF 408	1760	223	7.1	211	9.7	193	13.4	182	15.7	170	20.1
	2190	297	9.2	284	12.5	265	17.2	253	20.2	240	25.6
	2620	369	11.5	356	15.4	336	21.1	324	24.8	307	31.4
	3600	529	16.8	515	22.3	493	30.3	479	35.5	458	45.1
	4000	592	19.2	577	25.3	555	34.2	541	40.0	516	50.5

VACUUM

MODEL	RPM	10 inHG		12 inHG		14 inHG		16 inHG	
		CFM	BHP	CFM	BHP	CFM	BHP	CFM	BHP
HF 406	1760	135	4.2	125	5.0	113	5.8		
	2190	187	5.5	176	6.5	164	7.5	152	8.5
	2620	236	7.0	226	8.2	214	9.4	201	10.6
	3600	345	11.0	333	12.7	321	14.4	308	16.1
	4000	387	13.0	375	14.8	362	16.7	349	18.6
HF 408	1760	217	6.3	204	7.6	189	8.9		
	2190	292	8.1	278	9.6	264	11.1	247	12.8
	2620	364	10.1	351	11.8	337	13.6	321	15.4
	3600	523	15.3	511	17.5	497	19.8	482	22.1
	4000	584	17.7	573	20.1	560	22.6	545	25.1

Performance based on inlet air at standard temperature of 68° F, an ambient pressure of 14.7 psia and 36% relative humidity. For performance at non-standard conditions, contact your authorized Gardner Denver representative.



412, 514, 616 & 624 Dimensional Data

MODEL	WEIGHT	SHAFT DIAM.	A	B	C	D	E	F	G	H	J	K	L	M	N	P	Q	R	S	T	U	V
HF 412	291	1.5	13.32	4.81	9.62	4.81	4	23.98	13.29	3.89	8.66	6.66	9.62	4.66	13.32	4.81	13.32	6	7	10.75	11	.375 × .375 × 3.50
HF 514	667	1.875	19.1	6.37	15.0	7.5	5.5	31.6	16.29	3.53	12.0	10.56	14.18	7.5	20.5	7.81	19.92	9.96	13.0	17.31	18.5	0.5 × 0.5 × 3.25
HF 616	866	2.25	22.0	7.25	17.0	8.5	6.5	34.1	17.27	4.07	15.25	12.0	16.0	8.25	23.0	8.75	22.11	11.05	15.0	19.5	21.0	0.5 × 0.5 × 3.75
HF 624	1144	2.25	22.0	7.25	17.0	8.5	6.5	42.1	21.27	4.07	15.25	12.0	16.0	8.25	23.0	8.75	30.11	15.05	15.0	27.5	21.0	0.5 × 0.5 × 3.75

Dimensions shown in inches. Weights are in pounds and approximate. Dimensions for installation purposes provided upon request. 514 = 6" flange, 616 = 8" flange & 624 = 10" flange (150# flange connections); Hold down bolt hole diameter = .59"

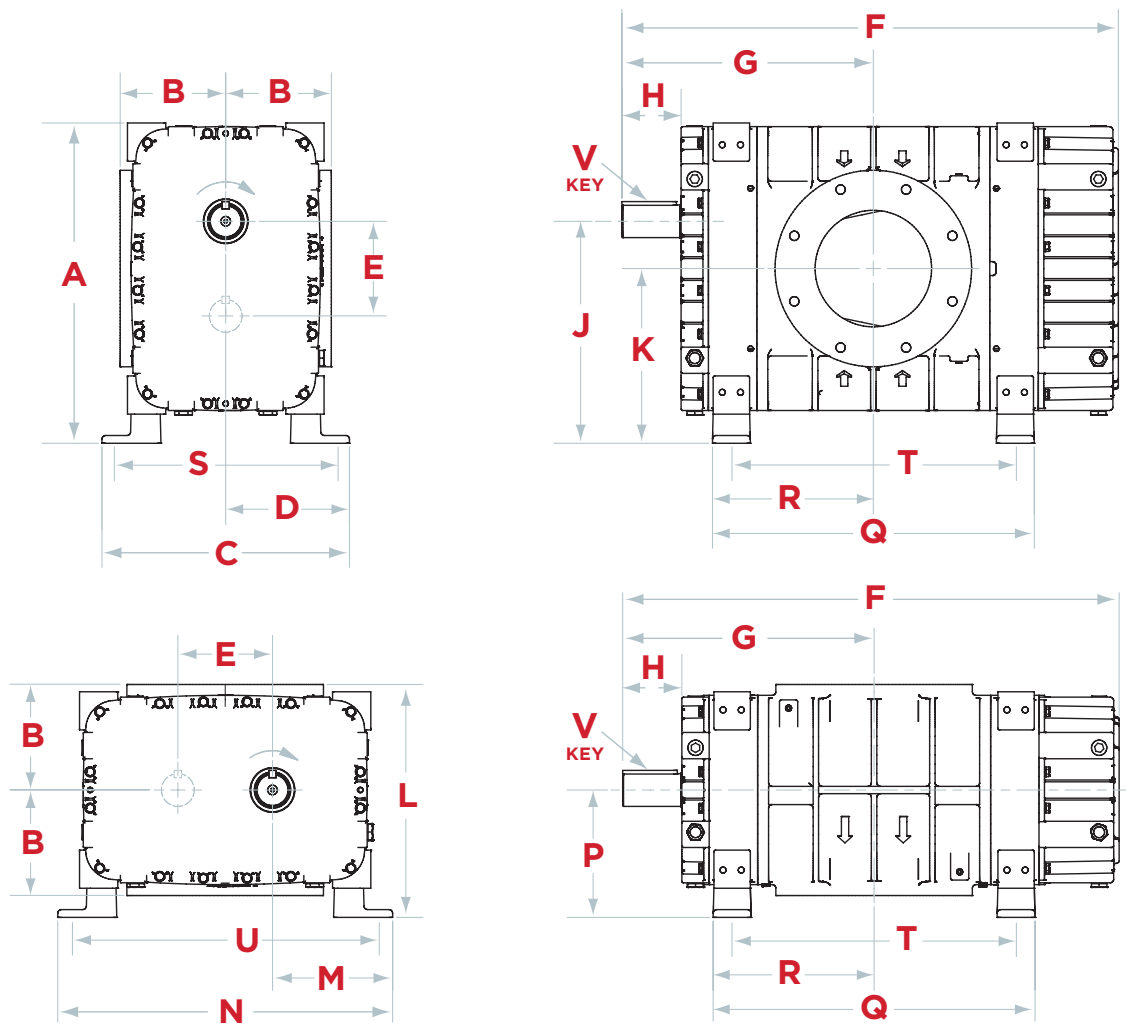

412, 514, 616, 624 Performance Data

PRESSURE

MODEL	RPM	5 PSI		7 PSI		10 PSI		12 PSI		15 PSI	
		CFM	BHP	CFM	BHP	CFM	BHP	CFM	BHP	CFM	BHP
HF 412	1760	350	10.8	331	14.4	305	20.3	289	24.4	375	39.2
	2190	461	14.0	442	18.7	415	26.0	399	31.1	482	47.6
	2620	570	17.5	551	23.1	524	32.0	507	38.1	722	67.3
	3600	815	25.9	795	33.8	766	46.0	748	54.4	818	75.6
	4000	913	29.5	893	38.4	863	52.0	845	61.3	936	86.1
4500	1034	34.2	1013	44.3	983	59.6	963	70.1			
HF 514	1000	252	9.5	225	13.0	188	18.5	165	22.2	408	45.0
	1600	519	15.2	493	21.1	457	29.9	436	35.9	676	62.7
	2200	783	21.6	758	29.6	723	41.9	703	50.2	942	80.9
	2800	1044	28.4	1019	38.8	986	54.4	967	65.0	1161	96.5
	3300	1258	34.6	1235	46.8	1203	65.3	1184	77.8	1463	119.0
4000	1555	43.8	1532	58.7	1503	81.2	1485	96.3			
HF 616	1000	444	16.3	405	21.7	353	30.1	323	35.8	718	72.9
	1600	880	25.4	840	34.7	788	48.7	757	58.3	1141	102.7
	2200	1305	36.3	1265	49.3	1212	69.1	1181	82.5	1553	134.3
	2800	1720	48.9	1680	65.7	1626	91.2	1594	108.4	1889	162.0
	3300	2058	60.8	2018	80.7	1963	111.0	1931	131.3		
HF 624	1000	673	23.2	620	31.5	547	44.5	502	53.6		
	1600	1310	37.7	1259	51.8	1187	73.5	1144	88.4		
	2200	1947	54.3	1896	74.1	1827	104.5	1785	125.1		
	2800	2581	72.7	2532	98.4	2464	137.4	2423	163.7		
	3300	3109	89.6	3060	120.0	2994	166.3	2955	197.4		

VACUUM

MODEL	RPM	10 inHG		12 inHG		14 inHG		16 inHG	
		CFM	BHP	CFM	BHP	CFM	BHP	CFM	BHP
HF 412	1760	331	19.9	309	24.5	284	29.6	370	43.1
	2190	444	25.5	421	30.8	397	36.7	481	51.3
	2620	554	31.5	532	37.6	508	44.2	728	71.8
	3600	798	46.9	752	53.6	754	63.0	826	80.8
	4000	895	53.9	875	62.4	851	71.3	946	92.6
4500	1015	63.2	994	72.5	971	82.3			
HF 514	1000	238	9.3	212	11.2	185	13.1	427	23.7
	1600	503	14.9	479	17.8	453	20.7	695	32.8
	2200	767	20.9	743	24.8	719	28.8	960	42.4
	2800	1028	27.3	1006	32.3	983	37.3	1180	50.7
	3300	1244	33.1	1223	38.9	1202	44.8	1484	63.0
4000	1545	41.7	1525	48.7	1505	55.8			
HF 616	1000	469	15.8	419	18.5	358	21.2	285	23.9
	1600	904	25.8	863	30.1	811	34.4	746	38.8
	2200	1335	36.7	1302	42.7	1258	48.8	1202	54.8
	2800	1760	48.8	1737	56.4	1701	64.1	1653	71.9
	3300	2111	59.6	2095	68.7	2066	77.7	2025	86.9
HF 624	1000	657	23.8	608	27.7	563	31.2	521	34.5
	1600	1341	38.4	1300	45.0	1262	51.4	1227	57.5
	2200	2014	53.8	1980	63.3	1949	72.4	1922	81.3
	2800	2676	70.0	2649	82.4	2626	94.4	2605	106.1
	3300	3218	84.3	3198	98.9	3181	113.3	3167	127.3

Performance based on inlet air at standard temperature of 68° F, an ambient pressure of 14.7 psia and 36% relative humidity. For performance at non-standard conditions, contact your authorized Gardner Denver representative.

825 Dimensional Data

MODEL	WEIGHT	SHAFT DIAM.	A	B	C	D	E	F	G	H	J	K	L	M	N	P	Q	R	S	T	U	V
HF 825	1820	3	28.75	9.5	20.76	10.38	8.75	46.99	24.51	4.58	10	14.38	19.5	10.38	29.5	10	31.5	15.58	18.02	28	24.75	.75 x .75 x 4.12

Dimensions shown in inches. Weight is in pounds and approximate. 12" Flange for Inlet/discharge connections (150 # flange connections). Hold down slot diameter 1.00"

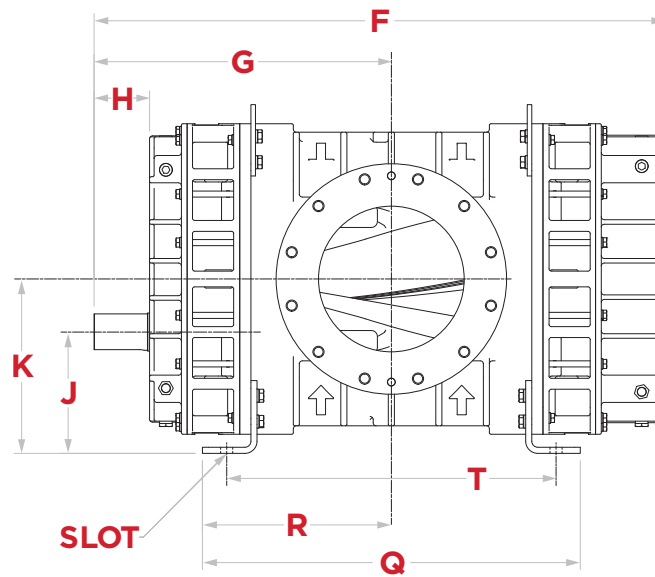
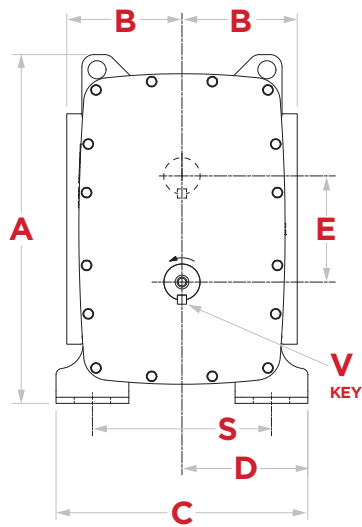
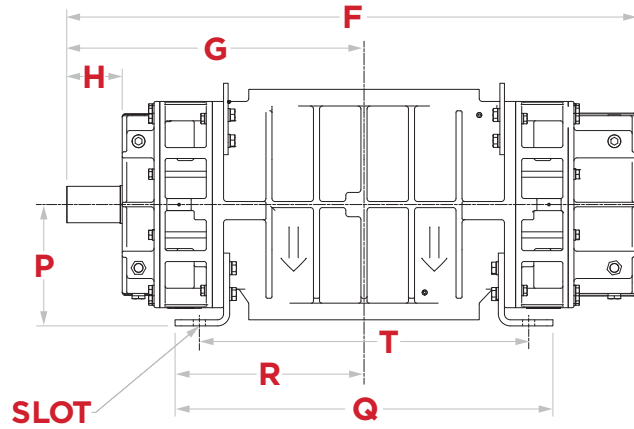
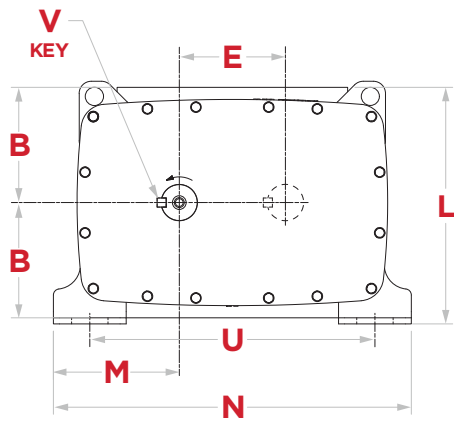

825 Performance Data

PRESSURE

MODEL	RPM	5 PSI		7 PSI		10 PSI		12 PSI		15 PSI	
		CFM	BHP	CFM	BHP	CFM	BHP	CFM	BHP	CFM	BHP
HF 825	1000	1470	44.4	1400	61.5	1310	87.7	1255	105.3	1180	132.1
	1200	1870	53.9	1805	74.7	1715	106.1	1665	127.5	1590	159.4
	1500	2460	69.0	2400	95.1	2315	134.6	2265	161.1	2200	201.4
	1800	3045	85.1	2985	116.5	2905	164.0	2860	196.1	2800	244.5
	2200	3805	107.9	3750	146.5	3675	204.7	3630	243.7	3575	302.8
	2500	4365	126.1	4310	169.9	4240	236.2	4200	280.7	4150	348.0

VACUUM

MODEL	RPM	10 inHG		12 inHG		14 inHG		16 inHG		17 inHG	
		CFM	BHP	CFM	BHP	CFM	BHP	CFM	BHP	CFM	BHP
HF 825	1000	1415	46.5	1340	56.5	1265	64.6	1195	67.6		
	1200	1820	55.3	1750	67.0	1675	77.1	1605	82.7		
	1500	2420	68.6	2350	82.7	2280	96.0	2210	105.5		
	1800	3010	82.1	2940	98.6	2870	114.9	2800	128.4	2775	132.6
	2200	3785	100.5	3715	120.3	3645	140.7	3575	159.3	3550	166.8
	2500	4350	114.5	4285	136.8	4215	160.2	4150	182.9	4120	192.6

Performance based on inlet air at standard temperature of 68° F, an ambient pressure of 14.7 psia and 36% relative humidity. For performance at non-standard conditions, contact your authorized Gardner Denver representative.

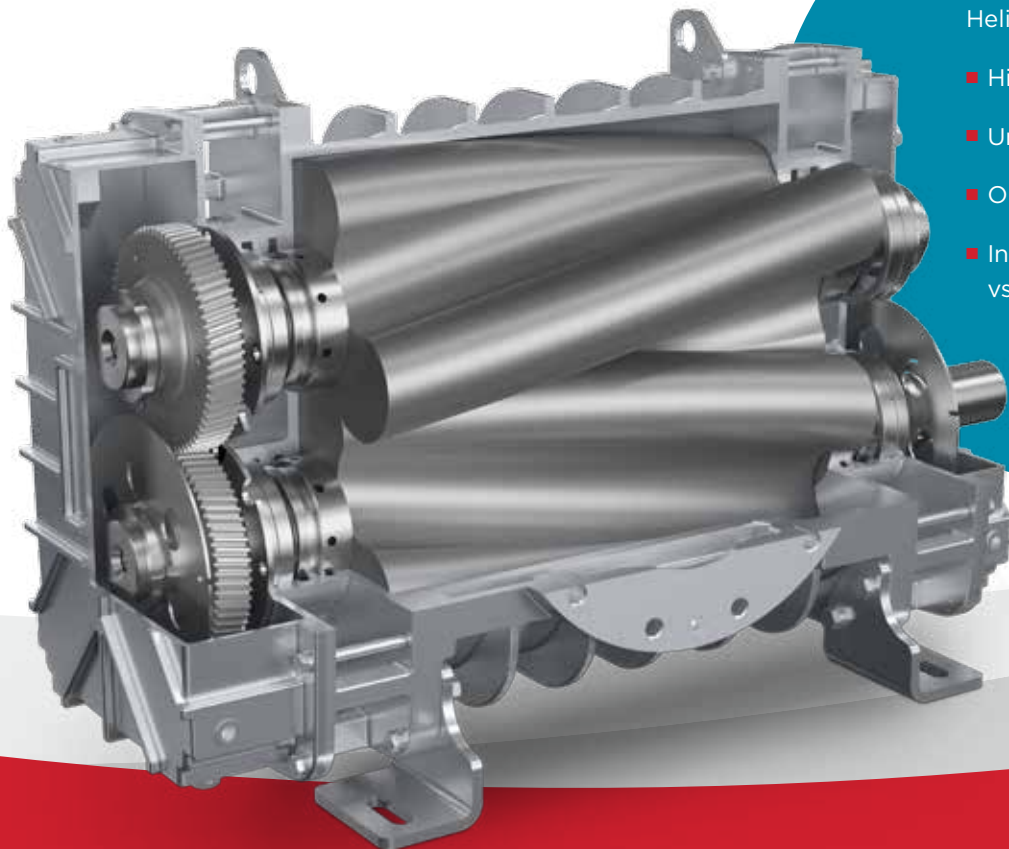

NEW!

HeliFlow 825 Series provides:

- Higher Flow Capabilities
- Unmatched Noise Reduction
- Optimized Heat Transfer
- Increased Shaft Strength vs. the Competition

The leader in every market we serve
by continuously improving all business processes
with a focus on innovation and velocity

**Gardner
Denver**[®]

Gardner Denver, Inc.

1800 Gardner Expressway
Quincy, IL 62305
866-428-4890

www.gardnerdenver.com/gdproducts



©2017 Gardner Denver, Inc. Printed in U.S.A.
PD-HF-IND 8th Ed. 2/17

