

ZONE		REV	DESCRIPTION	DATE	DWN	CHK
		A	RELEASED PER ECN 1045640			

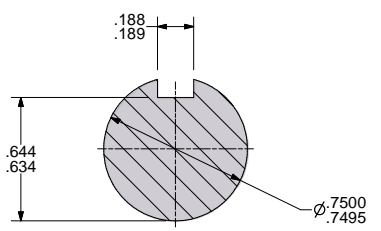
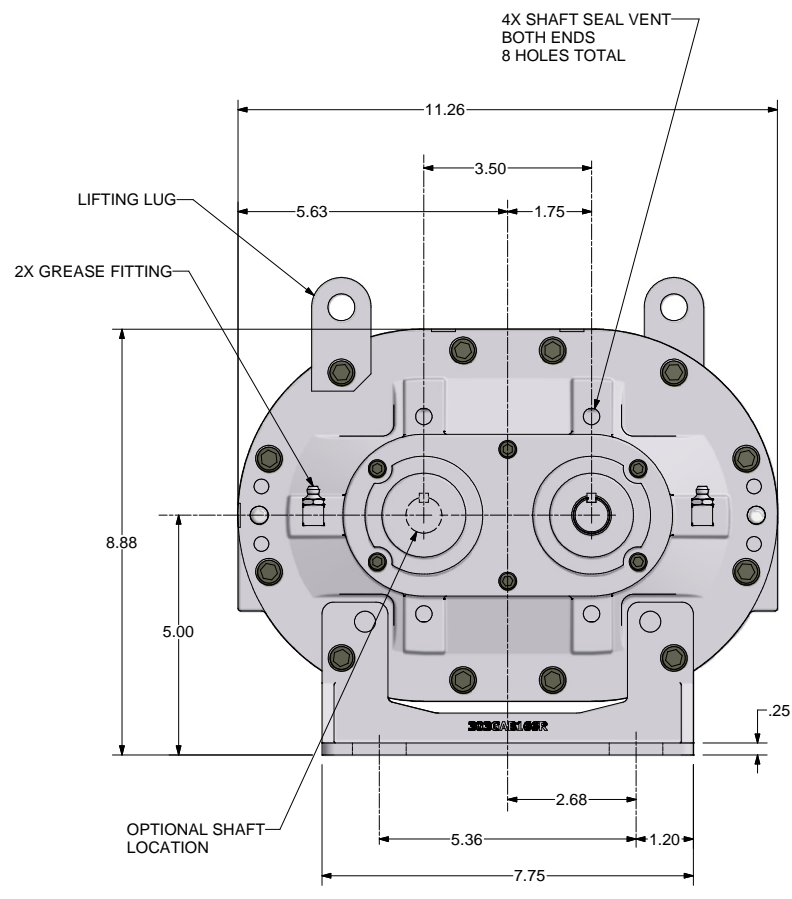
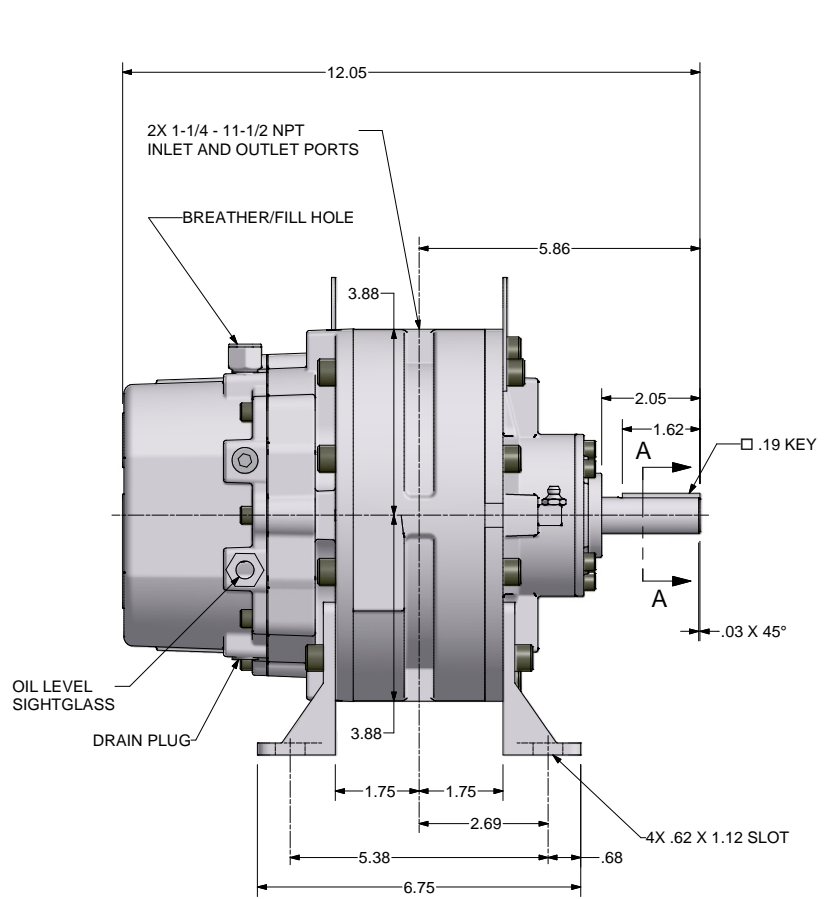

SECTION A-A  
SCALE 4 : 1

ALL ROTATIONS AND PORT LOCATIONS WHEN FACING SHAFT END

CONSTRUCTION	ROTATION	DISCHARGE PORT
HORIZONTAL RIGHT	CLOCK WISE (CW)	BOTTOM SIDE
	COUNTERCLOCKWISE (CCW)	TOP SIDE
HORIZONTAL LEFT	CLOCKWISE (CW)	TOP SIDE
	COUNTERCLOCKWISE (CCW)	BOTTOM SIDE

UNLESS OTHERWISE SPECIFIED DIMENSIONS ARE IN INCHES  
TOL. ON DECIMALS: X = ± .05  
TOL. ON DECIMALS: XX = ± .02  
TOL. ON DECIMALS: XXX = ± .01 AS SPECIFIED  
TOL. ON ANGLES: ± 0°-30'

FINISH OF CHAMBERS AND FILLETS TO CONFORM TO ROUGHEST ADJACENT AREA  
SURFACE ROUGHNESS MAXIMUM PER ASME B46.1  
FULL THREADS ON THE MINIMUM

CONFIDENTIAL - THE INFORMATION CONTAINED IN THIS DOCUMENT IS THE PROPERTY OF GARDNER DENVER, INC. IT IS NOT FOR PUBLIC DISCLOSURE. POSSESSION OF THE INFORMATION DOES NOT CONVEY ANY RIGHT TO LOAN, REPRODUCE, OR DISCLOSE THE INFORMATION. UNAUTHORIZED REPRODUCTION OR USE OF THE INFORMATION IS PROHIBITED. THIS DOCUMENT IS TO BE RETURNED TO GARDNER DENVER, INC. UPON THE COMPLETION OF THE PURPOSE FOR WHICH IT IS LOANED OR UPON REQUEST.

THIRD ANGLE PROJECTION

Gardner Denver Inc.  
Quincy, IL

DWN BY: RRB 4/17/2009  
E WSC  
C/D BY: RNS 4/17/2009

HEAT TREATMENT  
ENG. REF:

TITLE  
OUTLINE-BARE UNIT

SHR LEGEND GRS-SPL  
320GAB800

1 of 1