

ZONE		REV	DESCRIPTION	DATE	DWN	CHK
		A	RELEASED PER ECN 1045640			

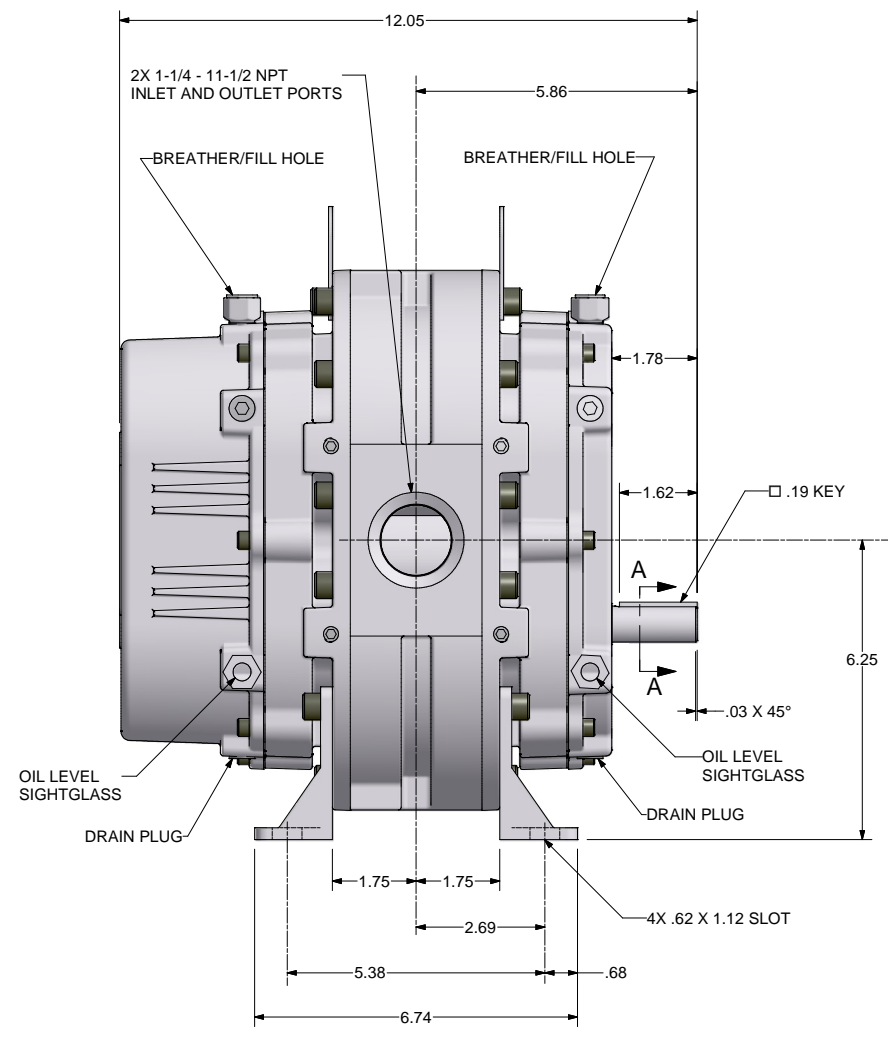

4X SHAFT SEAL VENT BOTH ENDS  
8 HOLES TOTAL

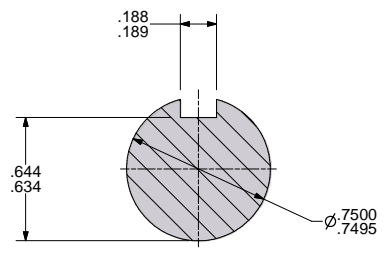
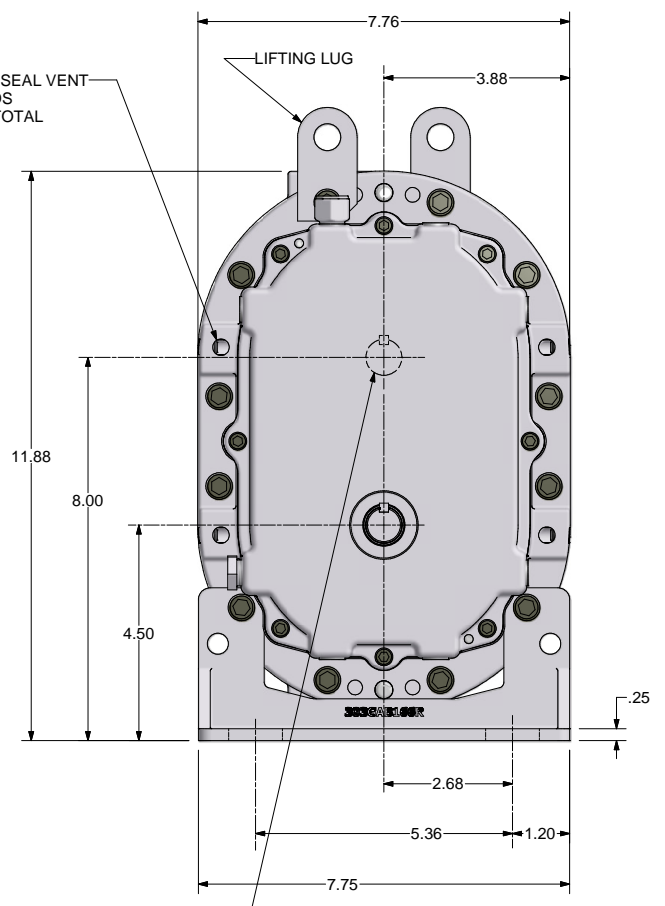

SECTION A-A  
SCALE 4 : 1

ALL ROTATIONS AND PORT LOCATIONS WHEN FACING SHAFT END

CONSTRUCTION	ROTATION	DISCHARGE PORT
VERTICAL BOTTOM	CLOCK WISE (CW)	LEFT SIDE
	COUNTERCLOCKWISE (CCW)	RIGHT SIDE
VERTICAL TOP	CLOCKWISE (CW)	RIGHT SIDE
	COUNTERCLOCKWISE (CCW)	LEFT SIDE

UNLESS OTHERWISE SPECIFIED DIMENSIONS ARE IN INCHES

TOL. ON DECIMALS: X = ± .05  
TOL. ON DECIMALS: XX = ± .02  
TOL. ON DECIMALS: XXX = ± .01 AS SPECIFIED  
TOL. ON ANGLES: ± 0°-30'

FINISH OF CHAMBERS AND FILLETS TO CONFORM TO ROUGHEST ADJACENT AREA  
SURFACE ROUGHNESS MAXIMUM PER ASME B46.1  
FULL THREADS ON THE MINIMUM

CONFIDENTIAL - THE INFORMATION CONTAINED IN THIS DOCUMENT IS THE PROPERTY OF GARDNER DENVER, INC. IT IS NOT FOR PUBLIC DISCLOSURE. POSSESSION OF THE INFORMATION DOES NOT CONVEY ANY RIGHT TO LOAN, REPRODUCE OR DISCLOSE THE INFORMATION. UNAUTHORIZED REPRODUCTION OR USE OF THE INFORMATION IS PROHIBITED. THIS DOCUMENT IS TO BE RETURNED TO GARDNER DENVER, INC. UPON THE COMPLETION OF THE PURPOSE FOR WHICH IT IS LOANED OR UPON REQUEST.

DIMENSIONING AND TOLERANCING PER ASME Y14.5M-1994  
THREADS PER ASME B1.1 GAGING SYSTEM Y14.5M-91 AND B1.203 & B1.203.3

Gardner Denver Inc.  
Quincy, IL

HEAT TREATMENT  
SHVR LEGEND DSL

OUTLINE-BARE UNIT

DWN BY: RRB 4/17/2009  
CVD BY: RNS 4/17/2009

WSC 317GAB800  
1 of 1