

| REVISION HISTORY | | DATE | DWN | CHK |
|------------------|-----|--------------------------|-----|-----|
| ZONE | REV | DESCRIPTION | | |
| | A | RELEASED PER ECN 1042521 | | |

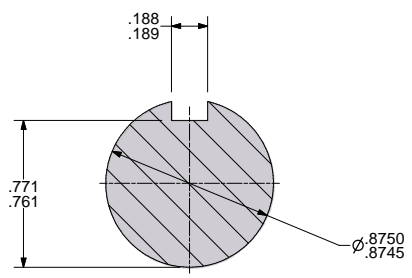
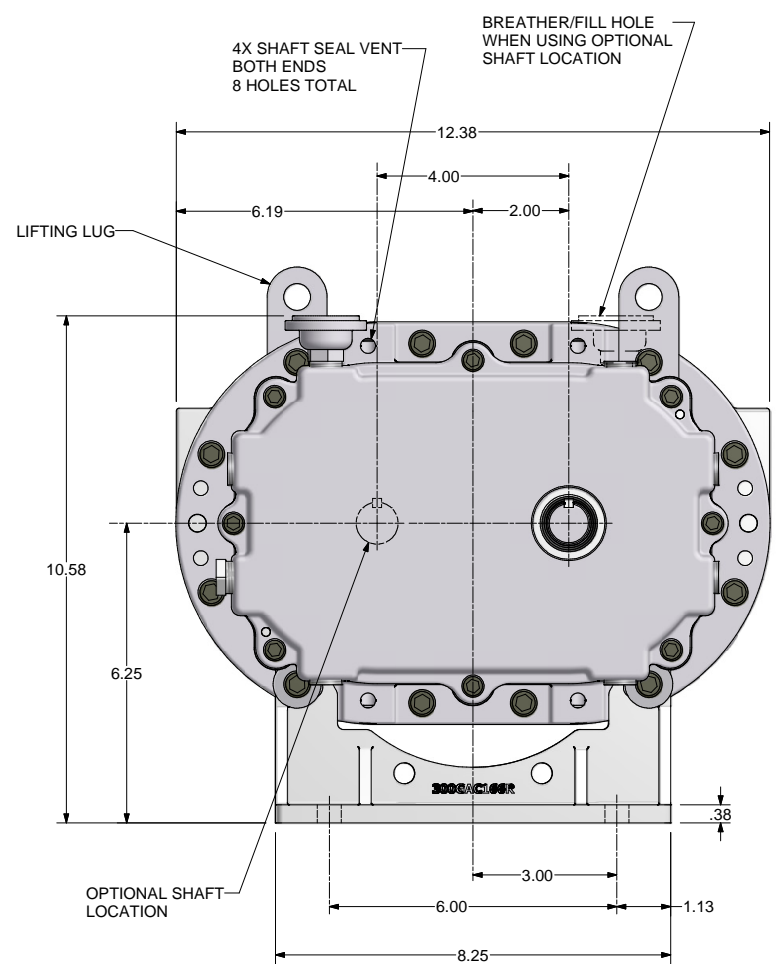
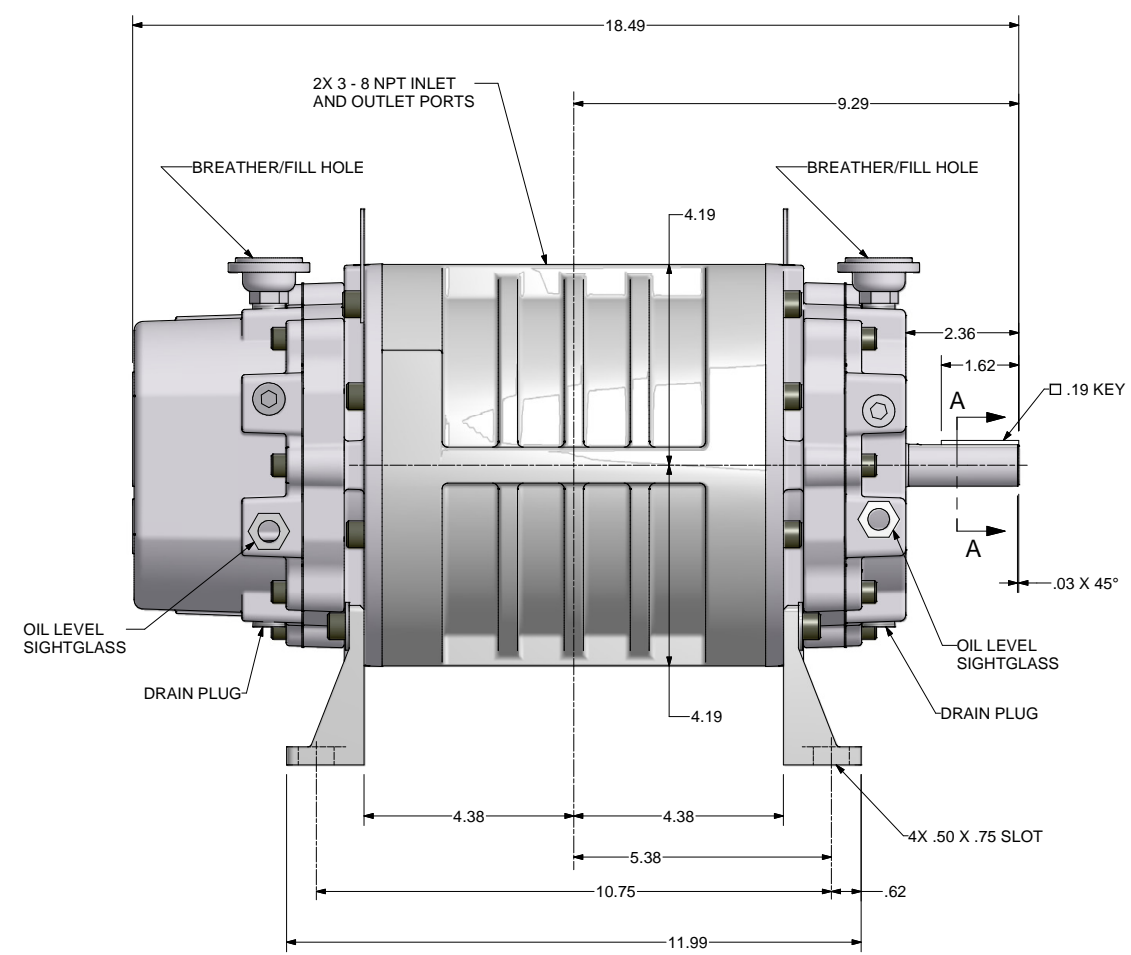

SECTION A-A
SCALE 4 : 1

ALL ROTATIONS AND PORT LOCATIONS WHEN FACING SHAFT END

| CONSTRUCTION | ROTATION | DISCHARGE PORT |
|------------------|------------------------|----------------|
| HORIZONTAL RIGHT | CLOCK WISE (CW) | BOTTOM SIDE |
| | COUNTERCLOCKWISE (CCW) | TOP SIDE |
| HORIZONTAL LEFT | CLOCKWISE (CW) | TOP SIDE |
| | COUNTERCLOCKWISE (CCW) | BOTTOM SIDE |

UNLESS OTHERWISE SPECIFIED DIMENSIONS ARE IN INCHES
 TOL. ON DECIMALS: X = ± .05
 TOL. ON DECIMALS: XX = ± .02
 TOL. ON DECIMALS: XXX = ± .01 AS SPECIFIED
 TOL. ON ANGLES: ± 0°30'

FINISH OF CHAMBERS AND FILLETS TO CONFORM TO ROUGHEST ADJACENT AREA
 SURFACE ROUGHNESS MAXIMUM PER ASME B46.1
 FULL THREADS TO THE MINIMUM

CONFIDENTIAL - THE INFORMATION CONTAINED IN THIS DOCUMENT IS THE PROPERTY OF GARDNER DENVER, INC. IT IS NOT FOR PUBLIC DISCLOSURE. POSSESSION OF THE INFORMATION DOES NOT CONVEY ANY RIGHT TO CLAIM, SELL OR DISCLOSE THE INFORMATION. UNAUTHORIZED REPRODUCTION OR USE OF THE INFORMATION IS PROHIBITED. THIS DOCUMENT IS TO BE RETURNED TO GARDNER DENVER, INC. UPON THE COMPLETION OF THE PURPOSE FOR WHICH IT IS LOANED OR UPON REQUEST.

DIMENSIONING AND TOLERANCING PER ASME Y14.5M-1994
 THREADS PER ASME B1.1 GAUGING SYSTEM Y14.5M-92, ANSI B1.203 & B1.203.3

Gardner Denver Inc.
 Quincy, IL

DWN BY: RRB 8/29/2008
 CTD BY: RNS 8/29/2008

HEAT TREATMENT
 4LR

ENG. REF:
 318GAC800

TITLE
 OUTLINE-BARE UNIT

4LR LEGEND DSL

THIRD ANGLE PROJECTION