

REVISION HISTORY				
ZONE	REV	DESCRIPTION	DATE	CHK
	A	RELEASED PER ECN 1045005		

8X 3/4-10 UNC-2B X  $\nabla$ 1.12  
EQUALLY SPACED ON  $\varnothing$ 9.50 BC  
BOTH SIDES

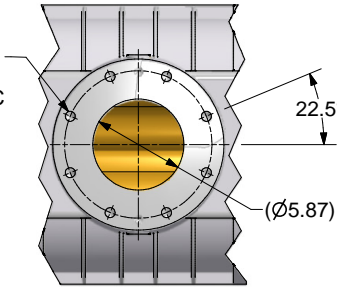

VIEW B-B  
SCALE 1 / 4

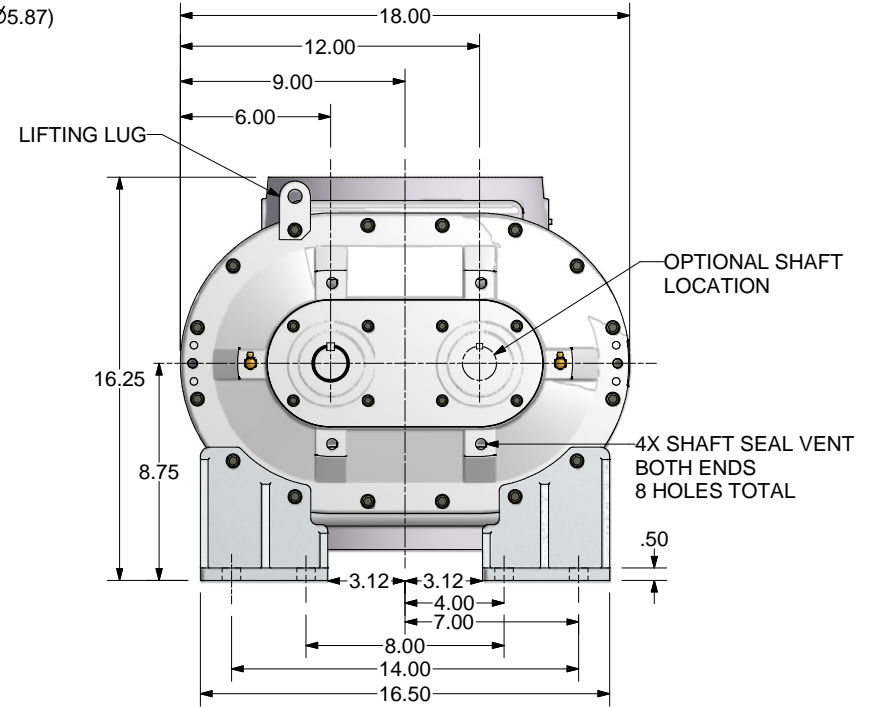
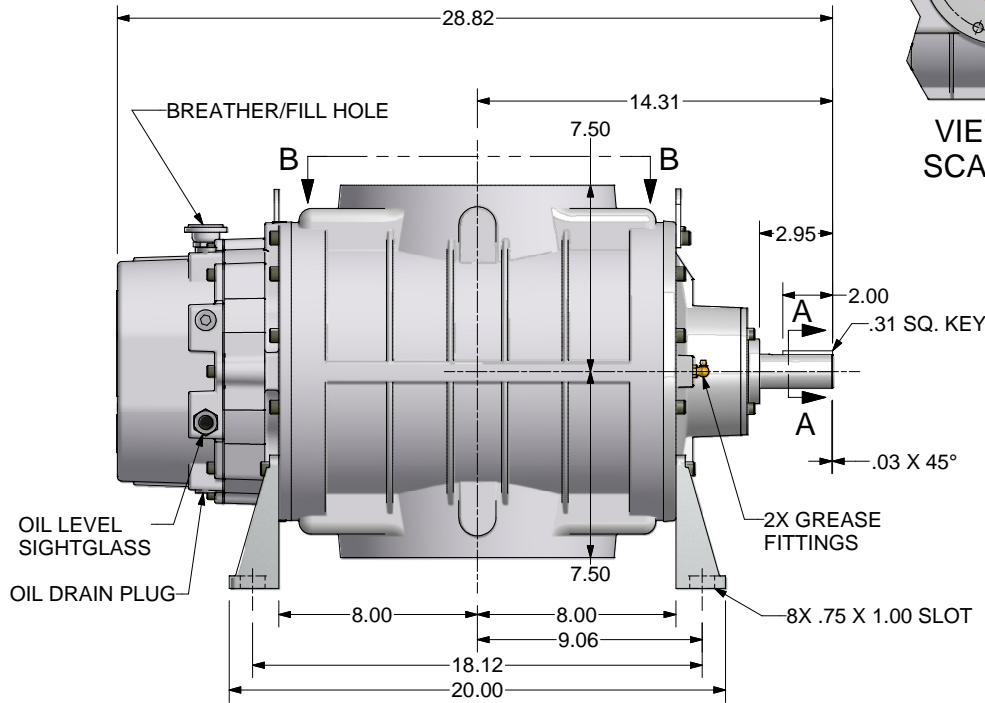

ALL ROTATIONS AND PORT LOCATIONS WHEN FACING SHAFT END

CONSTRUCTION	ROTATION	DISCHARGE PORT
HORIZONTAL RIGHT	CLOCKWISE (CW)	BOTTOM SIDE
	COUNTER CLOCKWISE (CCW)	TOP SIDE
HORIZONTAL LEFT	CLOCKWISE (CW)	TOP SIDE
	COUNTER CLOCKWISE (CCW)	BOTTOM SIDE

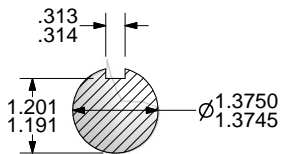

SECTION A-A  
SCALE 1 : 1

FINISH OF CHAMFERS AND FILLETS TO CONFORM TO ROUghest ADJACENT AREA.  
SURFACE ROUGHNESS MAXIMUM PER ASME B46.1.  
FULL THREAD DEPTHS ARE MINIMUM.

UNLESS OTHERWISE SPECIFIED DIMENSIONS ARE IN INCHES  
TOL ON DECIMALS: X =  $\pm$  .05  
TOL ON DECIMALS: XX =  $\pm$  .02  
TOL ON DECIMALS: XXX =  $\pm$  AS SPECIFIED  
TOL ON ANGLES:  $\pm$  0'-30'

THIRD ANGLE PROJECTION

CONFIDENTIAL - THE INFORMATION CONTAINED IN THIS DOCUMENT IS THE PROPERTY OF GARDNER DENVER, INC. IT IS NOT FOR PUBLIC DISCLOSURE. POSSESSION OF THE INFORMATION DOES NOT CONVEY ANY RIGHT TO LOAN, SELL OR DISCLOSE THE INFORMATION. UNAUTHORIZED REPRODUCTION OR USE OF THE INFORMATION IS PROHIBITED. THIS DOCUMENT IS TO BE RETURNED TO GARDNER DENVER, INC. UPON THE COMPLETION OF THE PURPOSE FOR WHICH IT IS LOANED OR UPON REQUEST.

DIMENSIONING AND TOLERANCING PER ASME Y14.5M-1994  
THREADS PER ASME B1.1 GAGING SYSTEM 21 U.O.S., ANSI B1.20.1 & B1.20.3

**Gardner Denver**  
Gardner Denver Inc.  
Quincy, IL

HEAT TREATMENT  
ENG. REF:

TITLE: **OUTLINE-BARE UNIT**  
6LR LEGEND GRS-SPL

DWN BY: TAM 3/16/2009  
CKD BY: RNS 3/16/2009

SCALE: 1/2.5

SHEET 1 OF 1