

REVISION HISTORY				
ZONE	REV	DESCRIPTION	DATE	CHK
	A	RELEASED PER ECN 1045005		

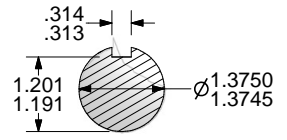
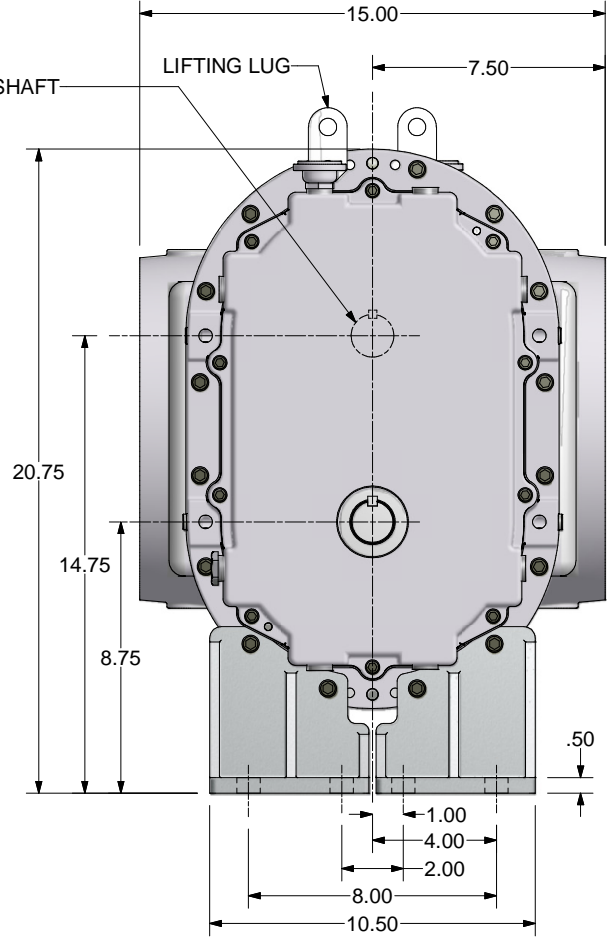
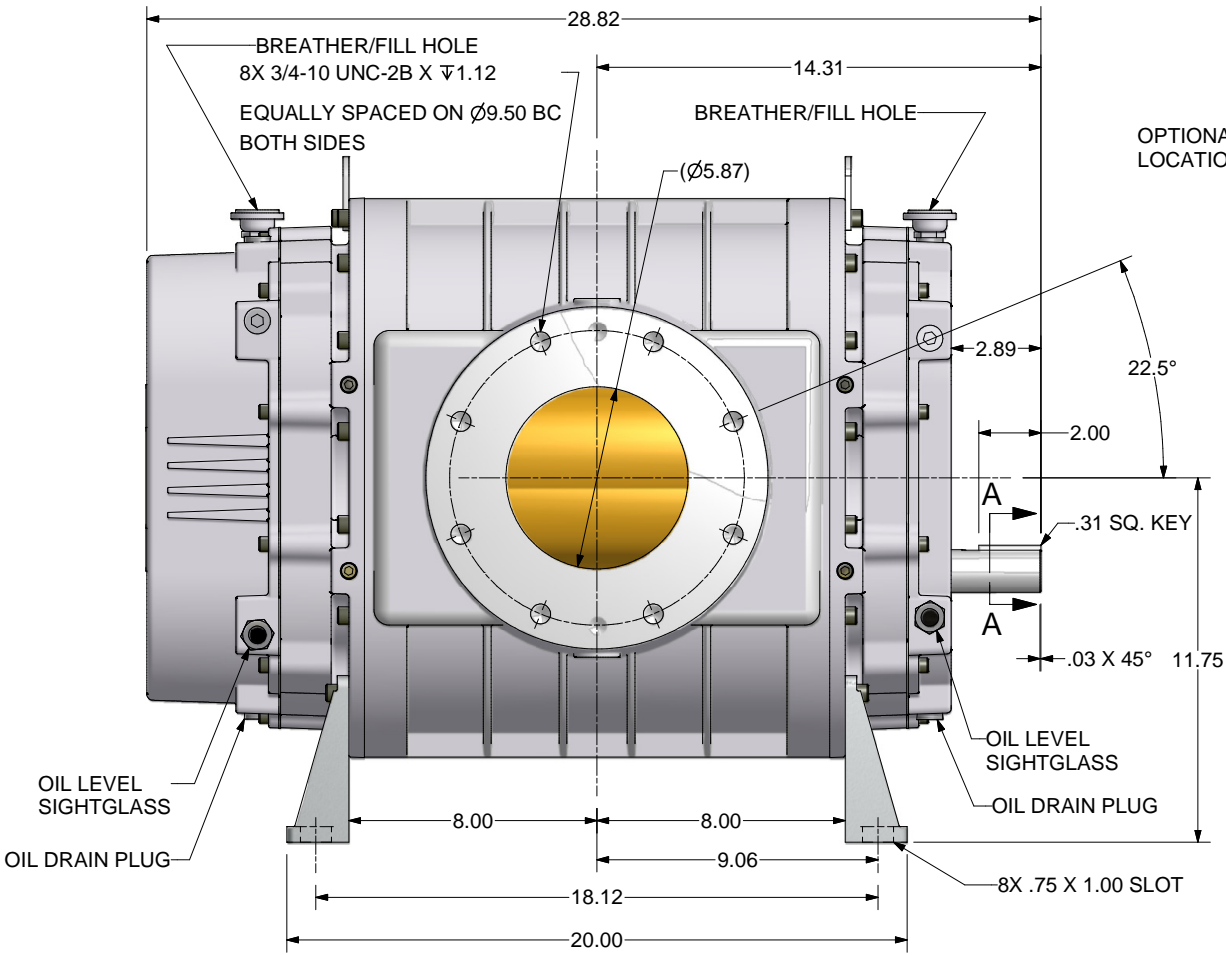

ALL ROTATIONS AND PORT LOCATIONS WHEN FACING SHAFT END

CONSTRUCTION	ROTATION	DISCHARGE PORT
VERTICAL BOTTOM	CLOCKWISE (CW)	LEFT SIDE
	COUNTER CLOCKWISE (CCW)	RIGHT SIDE
VERTICAL TOP	CLOCKWISE (CW)	RIGHT SIDE
	COUNTER CLOCKWISE (CCW)	LEFT SIDE

SECTION A-A  
SCALE 1 : 1

FINISH OF CHAMFERS AND FILLETS TO CONFORM TO ROUghest ADJACENT AREA. SURFACE ROUGHNESS MAXIMUM PER ASME B46.1. FULL THREAD DEPTHS ARE MINIMUM.

UNLESS OTHERWISE SPECIFIED DIMENSIONS ARE IN INCHES  
 TOL ON DECIMALS: .X = ± .05  
 TOL ON DECIMALS: .XX = ± .02  
 TOL ON DECIMALS: .XXX = ± AS SPECIFIED  
 TOL ON ANGLES: ± 0'-30'

THIRD ANGLE PROJECTION

CONFIDENTIAL - THE INFORMATION CONTAINED IN THIS DOCUMENT IS THE PROPERTY OF GARDNER DENVER, INC. IT IS NOT FOR PUBLIC DISCLOSURE. POSSESSION OF THE INFORMATION DOES NOT CONVEY ANY RIGHT TO LOAN, SELL OR DISCLOSE THE INFORMATION. UNAUTHORIZED REPRODUCTION OR USE OF THE INFORMATION IS PROHIBITED. THIS DOCUMENT IS TO BE RETURNED TO GARDNER DENVER, INC. UPON THE COMPLETION OF THE PURPOSE FOR WHICH IT IS LOANED OR UPON REQUEST.

DIMENSIONING AND TOLERANCING PER ASME Y14.5M-1994  
 THREADS PER ASME B1.1 GAGING SYSTEM 21 U.O.S., ANSI B1.20.1 & B1.20.3

**Gardner Denver** HEAT TREATMENT ENG. REF:

Gardner Denver Inc.  
 Quincy, IL

TITLE: **OUTLINE-BARE UNIT**  
 6LVR LEGEND DSL

DWN BY: TAM 3/16/2009  
 CKD BY: RNS 3/16/2009

SIZE: D  
 SCALE: 1/2

320GAF800

SHEET 1 OF 1