

REVISION HISTORY				
ZONE	REV	DESCRIPTION	DATE	CHK
	A	RELEASED PER ECN 1045005		

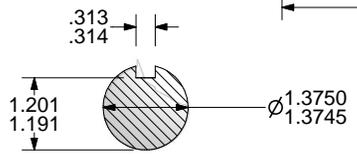
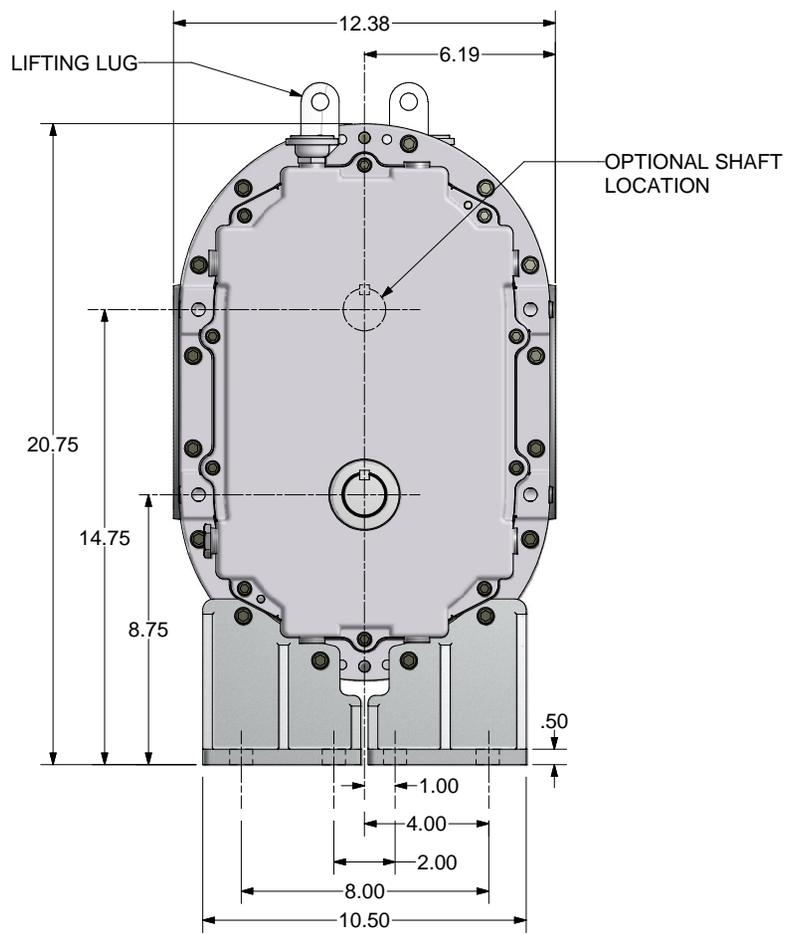
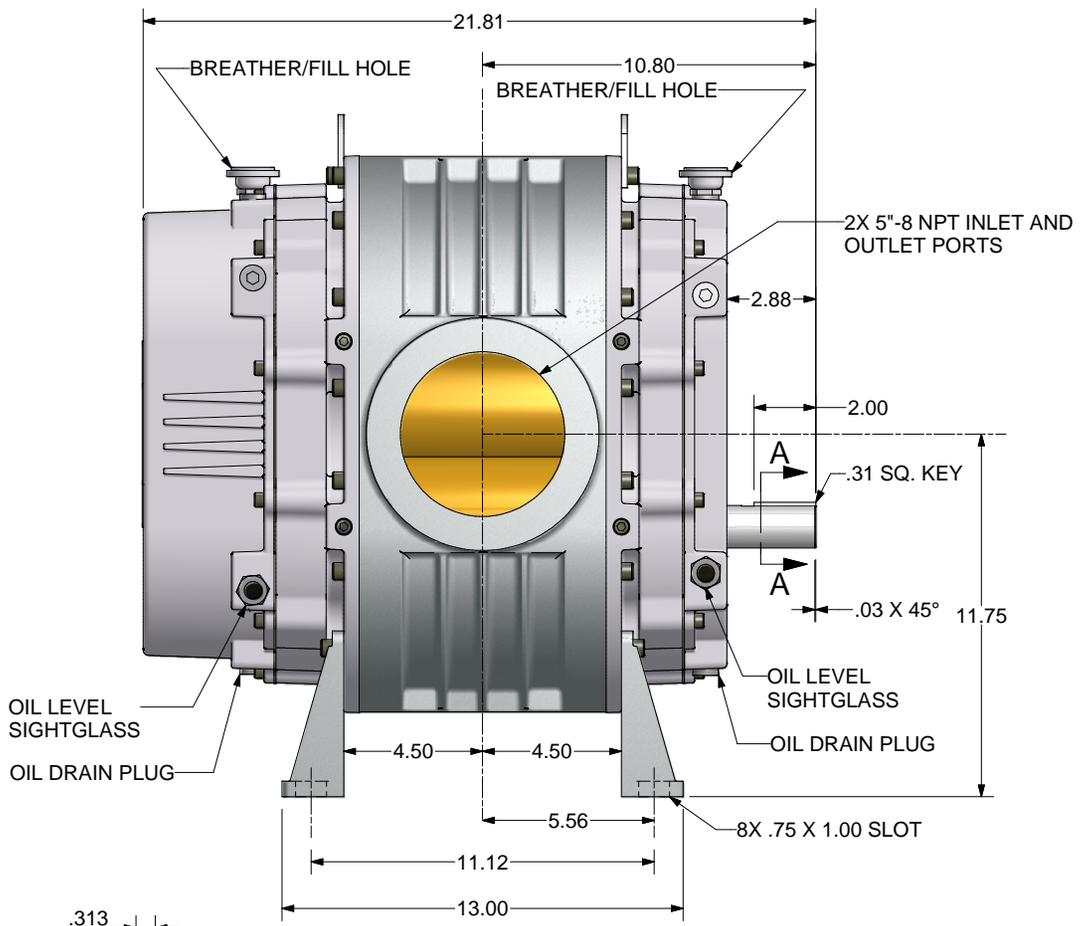

ALL ROTATIONS AND PORT LOCATIONS WHEN FACING SHAFT END

CONSTRUCTION	ROTATION	DISCHARGE PORT
VERTICAL BOTTOM	CLOCKWISE (CW)	LEFT SIDE
	COUNTER CLOCKWISE (CCW)	RIGHT SIDE
VERTICAL TOP	CLOCKWISE (CW)	RIGHT SIDE
	COUNTER CLOCKWISE (CCW)	LEFT SIDE

SECTION A-A
SCALE 1 : 1

UNLESS OTHERWISE SPECIFIED DIMENSIONS ARE IN INCHES
TOL. ON DECIMALS: X = ± .05
TOL. ON DECIMALS: XX = ± .02
TOL. ON DECIMALS: XXX = ± AS SPECIFIED
TOL. ON ANGLES: ± 0'-30'

THIRD ANGLE PROJECTION

FINISH OF CHAMFERS AND FILLETS TO CONFORM TO ROUghest ADJACENT AREA.
SURFACE ROUGHNESS MAXIMUM PER ASME B46.1.
FULL THREAD DEPTHS ARE MINIMUM.

CONFIDENTIAL - THE INFORMATION CONTAINED IN THIS DOCUMENT IS THE PROPERTY OF GARDNER DENVER, INC. IT IS NOT FOR PUBLIC DISCLOSURE. POSSESSION OF THE INFORMATION DOES NOT CONVEY ANY RIGHT TO LOAN, SELL OR DISCLOSE THE INFORMATION. UNAUTHORIZED REPRODUCTION OR USE OF THE INFORMATION IS PROHIBITED. THIS DOCUMENT IS TO BE RETURNED TO GARDNER DENVER, INC. UPON THE COMPLETION OF THE PURPOSE FOR WHICH IT IS LOANED OR UPON REQUEST.

DIMENSIONING AND TOLERANCING PER ASME Y14.5M-1994
THREADS PER ASME B1.1 GAGING SYSTEM 21 U.O.S., ANSI B1.20.1 & B1.20.3

Gardner Denver
Quincy, IL

HEAT TREATMENT
ENG. REF:

TITLE: **OUTLINE-BARE UNIT**
6MVR LEGEND DSL

Gardner Denver Inc.
Quincy, IL
DWN BY: TAM 3/9/2009
CKD BY: RNS 3/9/2009

SIZE: D
ENG. APPROVAL: [Signature]
SCALE: 1/2

316GAF800
SHEET 1 OF 1