

| REVISION HISTORY | | | | | |
|------------------|-----|--------------------------|------|-----|-----|
| ZONE | REV | DESCRIPTION | DATE | DWN | CHK |
| | A | RELEASED PER ECN 1045005 | | | |

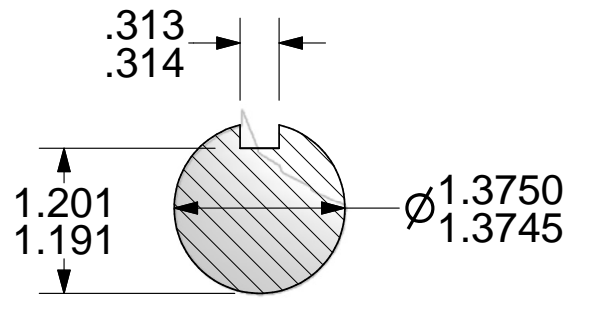
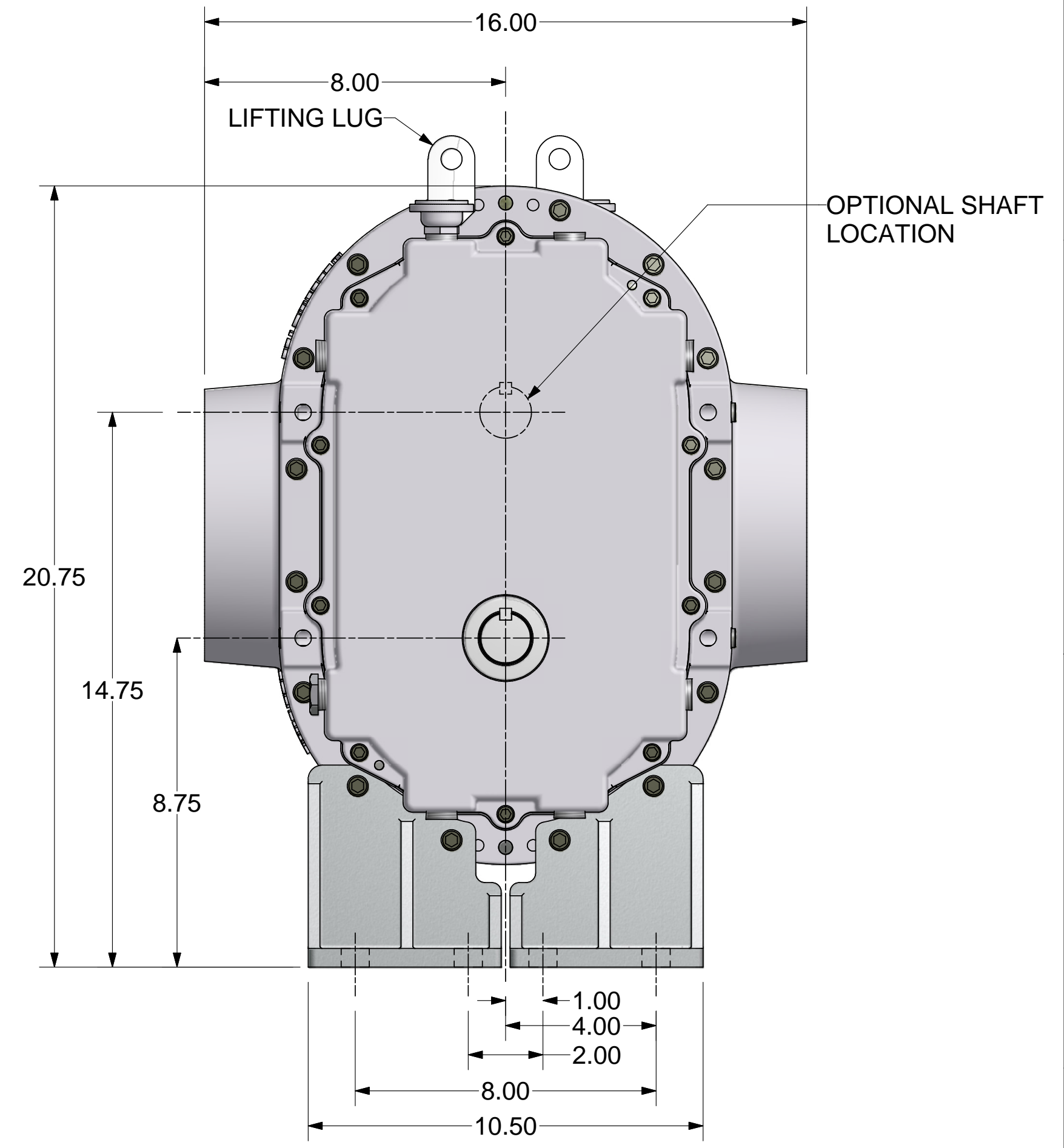
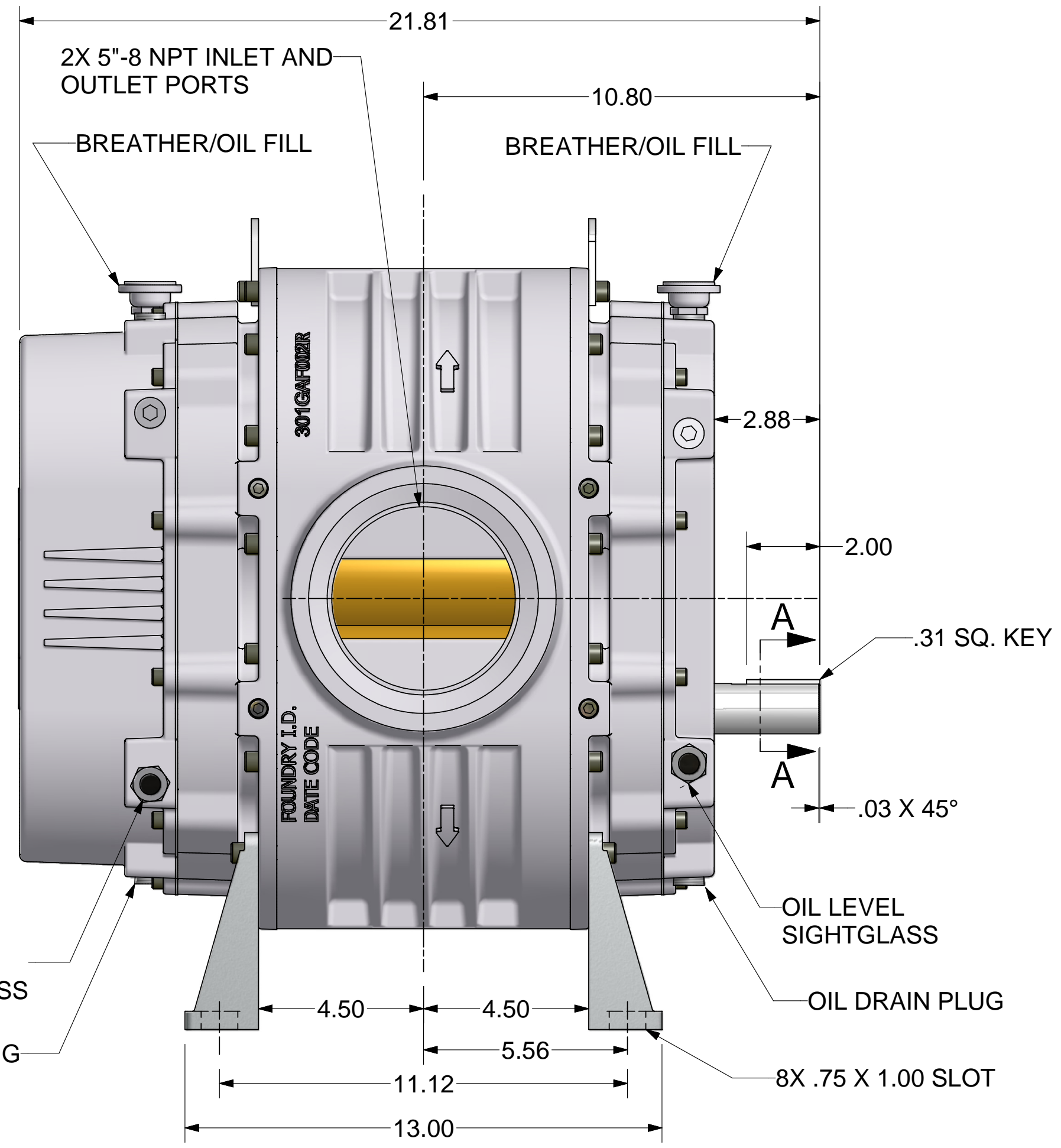

SECTION A-A
SCALE 1 : 1

ALL ROTATIONS AND PORT LOCATIONS WHEN FACING SHAFT END

| CONSTRUCTION | ROTATION | DISCHARGE PORT |
|-----------------|-------------------------|----------------|
| VERTICAL BOTTOM | CLOCKWISE (CW) | LEFT SIDE |
| | COUNTER CLOCKWISE (CCW) | RIGHT SIDE |
| VERTICAL TOP | CLOCKWISE (CW) | RIGHT SIDE |
| | COUNTER CLOCKWISE (CCW) | LEFT SIDE |

FINISH OF CHAMFERS AND FILLETS TO CONFORM TO ROUGHEST ADJACENT AREA. SURFACE ROUGHNESS MAXIMUM PER ASME B46.1. FULL THREAD DEPTHS ARE MINIMUM.

UNLESS OTHERWISE SPECIFIED DIMENSIONS ARE IN INCHES
TOL. ON DECIMALS: .X = ± .05
TOL. ON DECIMALS: .XX = ± .02
TOL. ON DECIMALS: .XXX = ± AS SPECIFIED
TOL. ON ANGLES: ± 0°-30'

THIRD ANGLE PROJECTION

CONFIDENTIAL - THE INFORMATION CONTAINED IN THIS DOCUMENT IS THE PROPERTY OF GARDNER DENVER, INC. IT IS NOT FOR PUBLIC DISCLOSURE. POSSESSION OF THE INFORMATION DOES NOT CONVEY ANY RIGHT TO LOAN, SELL OR DISCLOSE THE INFORMATION. UNAUTHORIZED REPRODUCTION OR USE OF THE INFORMATION IS PROHIBITED. THIS DOCUMENT IS TO BE RETURNED TO GARDNER DENVER, INC. UPON THE COMPLETION OF THE PURPOSE FOR WHICH IT IS LOANED OR UPON REQUEST.

DIMENSIONING AND TOLERANCING PER ASME Y14.5M-1994
THREADS PER ASME B1.1 GAGING SYSTEM 21 U.O.S., ANSI B1.20.1 & B1.20.3

Gardner Denver
Gardner Denver Inc.
Quincy, IL.

TITLE: **OUTLINE-BARE UNIT**
6MVQ LEGEND DSL

DWN BY TAM 3/13/2009
CKD BY RNS 3/13/2009

HEAT TREATMENT
ENG. REF:

SCALE: 1/2

SHEET 1 OF 1