



# Multistage Centrifugal Blower 870 Series

Hoffman and Lamson presents state-of-the-art technology in Multistage Centrifugal Blowers. This model offers a wide range of design features and incorporates energy efficiency improvements, complying with the strictest operational requirements of a variety of applications. Multistage blowers are ideally suited for operations where a variable flow at constant pressure is required. Hoffman and Lamson are worldwide leaders in Multistage Centrifugal Blower technology with thousands of units installed around the globe.

### Technical Data

- Number of Stages: 2-9 (60 Hz) 2-10 (50 Hz)
- Inlet Connection: 10" Flange, ANSI 125# Drilling
- Outlet Connection: 8" Flange, ANSI 125# Drilling
- Operating Speed: 3550 RPM (60 Hz), 2925 RPM (50 Hz)
- Casing Pressure: 25 PSIG (1.73 bar)
- Air Seals: Labyrinth Type - Carbon Ring Optional
- Bearings: Anti-friction, designed for extended L10 life
- Lubrication: AEON® CF Grease - Oil Optional
- Impeller: 25.0 inches (635 millimeters) Diameter (statically balanced)
- Impeller Tip Speed: 387 feet/second (117 meters/second)
- Drive Type: Direct Coupled (Inlet drive is standard)
- Drive Shaft: 2.25 inches (57.15 millimeters) Diameter
- Vibration: .235 in/sec. (5.97 mm/sec.) Peak Velocity
- Rotor: Balanced Per ISO 1940, ANSI S2.19

### Material Standard

- Casing: ASTM A48 Class 30B Gray Cast Iron - HT200 equivalent
- Bearing Housings: ASTM A48 Class 30 Cast Iron
- Bearing Cap: ASTM A48 Class 30 Cast Iron
- Tie Rods: ASTM F1554 GR.36 Zinc Plated Thrd. Rod
- Labyrinth Seal: ASTM B86 Z35631 Alloy Zinc Aluminum 12
- Carbon Ring Seal Optional: ASTM C695 Fine Grain Molded Graphite
- Joint Sealing: RTV Silicone Compound
- Baffle Rings: ASTM A240 Grade 304 Stainless Steel
- Balance Piston: ASTM A36 HR Structural Steel (5-10 Stage)
- Shaft: ASTM A322 Grade 4140CT Hot Rolled Steel - Stainless Steel Optional
- Impeller: ASTM B26-78 A355-T6 Cast Aluminum
- Base & Motor Pedestal: ASTM A36 Hot Rolled Structural Steel
- Isolation Base Pads: Suitable Resilient Material
- Finish: Universal Primer - Acrylic Topcoat

### Performance Air Map

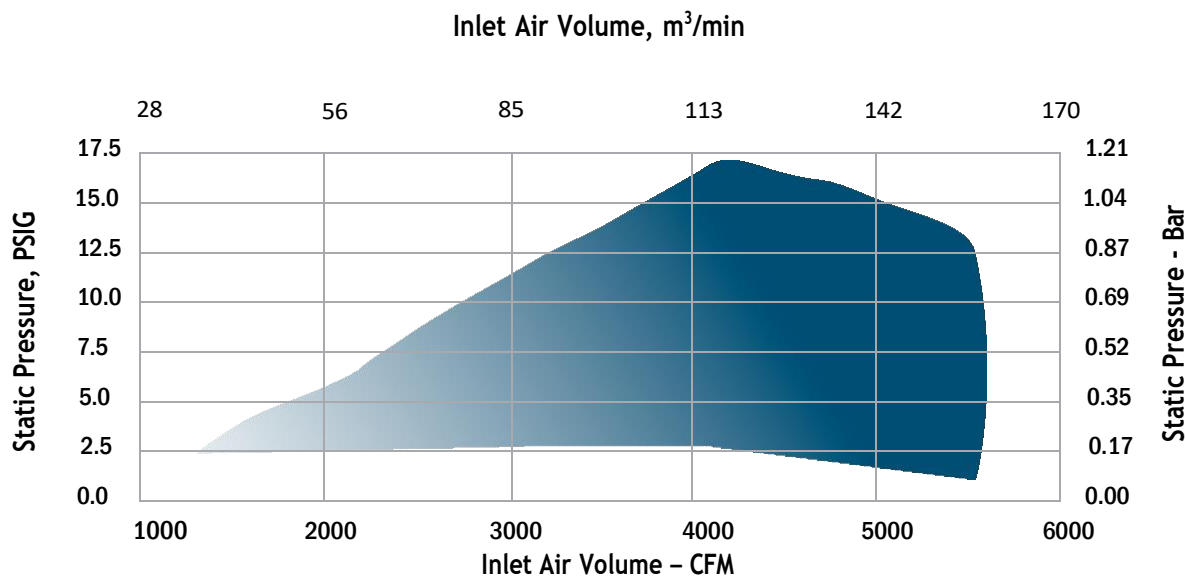

STANDARD CONDITIONS: 14.7 PSIA [1 Bar], 68°F [20°C], 36% RH, Speed: 3550 RPM

## General Arrangement

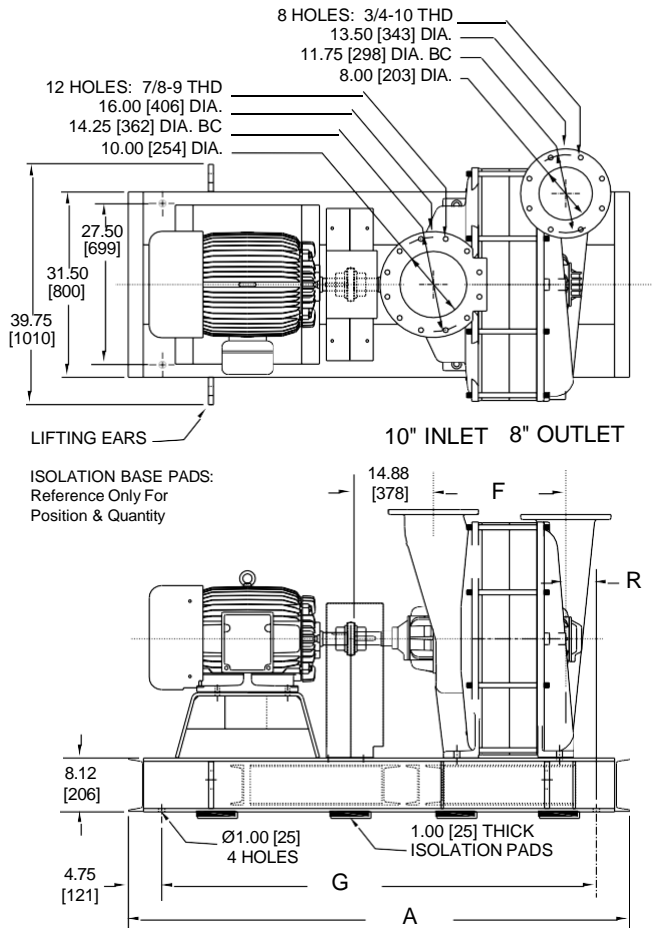

## Flange Orientation

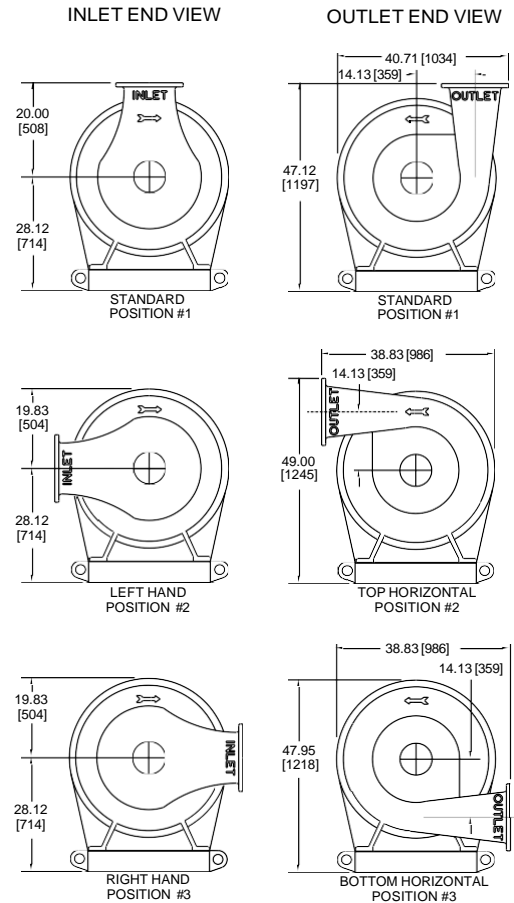

## Dimensional Data - inches [millimeters]

FRAME	A	F	G	R
872	75.00 [1905]	18.38 [467]	65.50 [1664]	1.00 [25]
873	75.00 [1905]	23.25 [591]	65.50 [1664]	1.00 [25]
874	84.00 [2134]	28.13 [714]	74.50 [1892]	1.00 [25]
875	99.00 [2515]	33.00 [838]	89.50 [2273]	1.00 [25]
876	99.00 [2515]	37.88 [962]	89.50 [2273]	1.00 [25]
877	104.00 [2642]	42.75 [1086]	94.50 [2400]	1.00 [25]
878	115.00 [2921]	47.63 [1210]	105.50 [2680]	1.00 [25]
879	115.00 [2921]	52.50 [1334]	105.50 [2680]	1.00 [25]
8710	120.00 [3048]	57.38 [1457]	110.50 [2807]	1.00 [25]

## Weight – lb [kg] & Inertia – lb-ft<sup>2</sup> [kg-m<sup>2</sup>]

FRAME	PKG. LESS MOTOR	BARE UNIT	WK2
872	2400 [1089]	1800 [816]	25 [1.05]
873	3020 [1370]	2220 [1007]	38 [1.58]
874	3540 [1606]	2640 [1197]	50 [2.09]
875	4060 [1842]	3060 [1388]	62 [2.61]
876	4580 [2077]	3480 [1578]	74 [3.12]
877	5000 [2268]	3900 [1769]	87 [3.65]
878	5520 [2504]	4320 [1960]	99 [4.17]
879	5940 [2694]	4740 [2150]	112 [4.70]
8710	6460 [2930]	5160 [2341]	124 [5.22]

## Product Notes

- Information is approximate, subject to change without notice, and not for construction use unless certified
- Position #1 is standard inlet & outlet orientation
- A and G dimensions may vary depending on motor frame size
- Performances noted are typical and not job specific
- Consult authorized sales representative for job specific blower or exhauster performance sizing
- Factory ASME PTC-10 test offered for performance verification
- For components that exceed 4,000 lb., machined pads are used. Height of the components on the base frame increase by 0.88 inches due to the use of machined pads



200 Simko Blvd.  
Charleroi, PA 15022  
USA  
HOFFMANandLAMSON.com